

Contains

Operating Manual

for

VXI SIGNAL GENERATOR

3271

9 kHz - 2.4 GHz

Part number A8130

Issue 9

Creation date May 2001

VXI SIGNAL GENERATOR

3271

9kHz-2.4GHz

This manual applies to instruments with software issues of 2.00 and higher.

© Racal Instruments Ltd. 2001

No part of this book may be reproduced or transmitted in any form or by any means, electronic or mechanical, including photocopying, or recorded by any information storage or retrieval system, without permission in writing by Racal Instruments Ltd.

Printed in the UK

Manual part no. A8130

Issue 9

May 2001

About this manual

This manual explains how to use the 3271 AM/FM Signal Generator.

Intended audience

Persons engaged on work relating to equipment who have a need for accurately generated signals in the VHF and UHF spectrum.

Structure

Chapter 1

Main features and performance data.

Chapter 2

Installation and power-up.

Chapter 3

Programming with keywords and sample programs.

Chapter 4

Brief technical description.

Chapter 5

Instructions for doing acceptance testing.

Document conventions

The following conventions apply throughout this manual:

PF OUT Titles marked on the instrument panel are shown in capital letters

CONTENTS

PRECAUTIONS	iv
PRECAUTIONS	vi
VORSICHTSMASSNAHMEN.....	viii
PRECAUZIONI.....	x
PRECAUCIONES.....	xii
CHAPTER 1 GENERAL INFORMATION	1-1
CHAPTER 2 INSTALLATION AND POWER-UP.....	2-1
CHAPTER 3 PROGRAMMING	3-1
Miscellaneous commands	3-29
Status byte.....	3-33
Error messages.....	3-43
CHAPTER 4 TECHNICAL DESCRIPTION.....	4-1
CHAPTER 5 ACCEPTANCE TESTING	5-1
Test procedures.....	5-5
INDEX	INDEX-1

GENERAL
INFORMATION

INSTALLATION

PROGRAMMING

TECHNICAL
DESCRIPTION

ACCEPTANCE
TESTING

INDEX

ADDRESSES

Precautions

WARNING

CAUTION

Note

These terms have specific meanings in this manual:

WARNING

information to prevent personal injury.

CAUTION



information to prevent damage to the equipment.

Note

important general information.

Symbols

The meaning of hazard symbols appearing on the equipment is as follows:-

Symbol	Description
	General hazard
	Toxic hazard
	Static sensitive components

General conditions of use

This product is designed and tested to comply with the requirements of IEC/EN61010-1 'Safety requirements for electrical equipment for measurement, control and laboratory use', for Class III portable equipment and is for use in a pollution degree 2 environment. The equipment is designed to operate from an installation category I supply.

Equipment should be protected from the ingress of liquids and precipitation such as rain, snow, etc. When moving the equipment from a cold to a hot environment, it is important to allow the temperature of the equipment to stabilise before it is connected to the supply to avoid condensation forming. The equipment must only be operated within the environmental conditions specified in Chapter 1 'Performance data' in the Operating/Instruction manual, otherwise the protection provided by the equipment may be impaired.

This product is not approved for use in hazardous atmospheres or medical applications. If the equipment is to be used in a safety-related application, e.g. avionics or military applications, the suitability of the product must be assessed and approved for use by a competent person.

WARNING



Electrical hazards (DC supply voltage)

This equipment conforms with IEC safety Class III, meaning that for continued safety it must only be connected to supplies and signal sources which conform to 'Separated Extra-Low Voltage' (SELV and SELV-E) voltage and insulation requirements. No hazardous voltages are generated internally. See under 'Performance data' in Chapter 1 for the maximum permitted voltage levels that can be applied.

WARNING **Fire hazard**

Access to the supply fuses is through the removal of an external cover. Removal of the covers should be referred to qualified Personnel. For continued protection against fire, fuses must only be replaced with those of the correct rating and type.

WARNING **Toxic hazards**

Some of the components used in this equipment may include resins and other materials which give off toxic fumes if incinerated. Take appropriate precautions, therefore, in the disposal of these items.

WARNING **Beryllia**

Beryllia (beryllium oxide) is used in the construction of some of the components in this equipment. This material, if incorrectly handled, could cause a danger to health - refer to the Maintenance part of the Service Manual for safe handling precautions.

WARNING **Beryllium copper**

Some mechanical components within this instrument are manufactured from beryllium copper. This is an alloy with a beryllium content of approximately 5%. It represents no risk in normal use.

The material should not be machined, welded or subjected to any process where heat is involved.

It must be disposed of as "special waste".

It must NOT be disposed of by incineration.

CAUTION **Static sensitive components**

This equipment contains static sensitive components which may be damaged by handling - refer to the Maintenance part of the Service Manual for handling precautions.

CAUTION**Voltage restraint**

Excessive voltages can damage the instrument. Ensure that applied signal voltages are within the limits marked on the front panel.

CAUTION**Installation**

Never insert or remove the instrument when the mainframe is already powered up. Always switch the mainframe off first and then on again afterwards, then run the resource manager again for normal operation.

Précautions

WARNING

CAUTION

Note

Les termes suivants ont, dans ce manuel, des significations particulières:

WARNING

contient des informations pour éviter toute blessure au personnel.

CAUTION

contient des informations pour éviter les dommages aux équipements.

Note

contient d'importantes informations d'ordre général.

Symboles signalant un risque

La signification des symboles liés à cet équipement est la suivante:

Symbole

Nature du risque



Risques généraux



Danger produits toxiques

Conditions générales d'utilisation

Ce produit a été conçu et testé pour être conforme aux exigences des normes CEI/EN61010-1 "Règles de sécurité pour appareils électriques de mesure, de régulation et de laboratoire", pour des équipements Classe III portables et pour une utilisation dans un environnement de pollution de niveau 2. Cet équipement est conçu pour fonctionner à partir d'une alimentation de catégorie I.

Cet équipement doit être protégé de l'introduction de liquides ainsi que des précipitations d'eau, de neige, etc... Lorsqu'on transporte cet équipement d'un environnement chaud vers un environnement froid, il est important de laisser l'équipement se stabiliser en température avant de le connecter à une alimentation afin d'éviter toute formation de condensation. L'appareil doit être utilisé uniquement dans le cadre des conditions d'environnement spécifiées au chapitre 1 "Performance data" du manuel d'utilisation, toute autre utilisation peut endommager les systèmes de protection.

Ce produit n'est pas garanti pour fonctionner dans des atmosphères dangereuses ou pour un usage médical. Si l'équipement doit être utilisé pour des applications en relation avec la sécurité, par exemple des applications militaires ou aéronautiques, la compatibilité du produit doit être établie et approuvée par une personne compétente.

WARNING



Sécurité électrique (tension d'alimentation continue)

Cet équipement est conforme aux normes de sécurité CEI Classe III, c'est-à-dire qu'il ne doit être connecté qu'à des sources d'alimentation ou de signaux qui suivent les recommandations de tension et d'isolement du type "Tension extra-faible séparée" (SELV at SELV-E). Aucune tension dangereuse n'est générée en interne. "Performance data" dans le chapitre 1 du manuel d'utilisation précise les niveaux de tension maximum acceptables en entrée.

WARNING **Risque lié au feu**

L'accès aux fusibles d'alimentation se fait après démontage d'un couvercle de protection extérieur. Cette manipulation est à la charge d'un personnel qualifié. Pour une protection continue contre le feu, les fusibles de remplacement doivent être de type et de valeur adaptés.

WARNING **Danger produits toxiques**

Certains composants utilisés dans cet appareil peuvent contenir des résines et d'autres matières qui dégagent des fumées toxiques lors de leur incinération. Les précautions d'usages doivent donc être prises lorsqu'on se débarrasse de ce type de composant.

WARNING **Le Béryllia**

Le Béryllia (oxyde de Béryllium) entre dans la composition de certains composants de cet appareil. Cette matière peut représenter un danger pour la santé s'il elle n'est pas manipulée de façon correcte - se référer à la partie "Maintenance" du "Manuel de Maintenance" pour les précautions de manipulation.

WARNING **Bronze au béryllium**

Dans cet équipement, certaines pièces mécaniques sont à base de bronze au béryllium. Il s'agit d'un alliage dans lequel le pourcentage de béryllium ne dépasse pas 5%. Il ne présente aucun danger en utilisation normale.

Toutefois, cet alliage ne doit pas être travaillé, soudé ou soumis à un processus qui implique l'utilisation d'une source de chaleur.

En cas de destruction, il sera entreposé dans un container spécial. IL ne devra pas être détruit par incinération.

Vorsichtsmaßnahmen

WARNING

CAUTION

Note

Diese Hinweise haben eine bestimmte Bedeutung in diesem Handbuch:

WARNING

dienen zur Vermeidung von Verletzungsrisiken.

CAUTION

dienen dem Schutz der Geräte.

Note

enthalten wichtige Informationen.

Gefahrensymbole

Die Gefahrensymbole auf den Geräten sind wie folgt:

Symbol

Gefahrenart



Allgemeine Gefahr



Warnung vor giftigen Substanzen

Allgemeine Hinweise zur Verwendung

Dieses Produkt wurde entsprechend den Anforderungen von IEC/EN61010-1 "Sicherheitsanforderungen für elektrische Ausrüstung für Meßaufgaben, Steuerung und Laborbedarf", Klasse III, transportabel zur Verwendung in einer Grad 2 verunreinigten Umgebung, entwickelt und getestet. Dieses Gerät ist für Netzversorgung Klasse I zugelassen.

Das Gerät sollte vor dem Eindringen von Flüssigkeiten sowie vor Regen, Schnee etc. geschützt werden. Bei Standortänderung von kalter in wärmere Umgebung sollte das Gerät wegen der Kondensation erst nach Anpassung an die wärmere Umgebung mit dem Netz verbunden werden. Das Gerät darf nur in Umgebungsbedingungen wie in Kapitel 1 "Leistungsdaten (Performance data)" der Bedienungsanleitung beschrieben, betrieben werden; ansonsten wird der vom Gerät vorgesehene Schutz des Anwenders beeinträchtigt.

Dieses Produkt ist nicht für den Einsatz in gefährlicher Umgebung (z.B. Ex-Bereich) und für medizinische Anwendungen geprüft. Sollte das Gerät für den Einsatz in sicherheitsrelevanten Anwendungen wie z.B. im Flugverkehr oder bei militärischen Anwendungen vorgesehen sein, so ist dieser von einer für diesen Bereich zuständigen Person zu beurteilen und genehmigen.

WARNING



Elektrische Schläge (Gleichspannungsversorgung)

Dieses Gerät entspricht der IEC Sicherheitsklasse III. Aus Sicherheitsgründen darf es nur an Netzgeräte und Signalquellen angeschlossen werden, die in Spannung und Isolation der SELV und SELV-E Richtlinie genügen ("Getrennte Niederspannung"). Im Gerät werden keine gefährlichen Spannungen erzeugt. Im Handbuch, Kapitel 1, "Performance data" (Leistungsdaten), werden die anschließbaren Höchstspannungen definiert.

WARNING **Brandgefahr**

Der Zugriff auf die Netzsicherungen geschieht durch die Entfernung einer Abdeckung. Die Entfernung der Abdeckungen sollte nur von qualifiziertem Personal ausgeführt werden. Zum Schutz gegen Brandgefahr dürfen die Sicherungen nur gegen solche gleichen Typs und Wertes ausgetauscht werden.

WARNING **Warnung vor giftigen Substanzen**

In einigen Bauelementen dieses Geräts können Epoxyharze oder andere Materialien enthalten sein, die im Brandfall giftige Gase erzeugen. Bei der Entsorgung müssen deshalb entsprechende Vorsichtsmaßnahmen getroffen werden.

WARNING **Beryllium Oxid**

Beryllium Oxid wird in einigen Bauelementen verwendet.

Bei inkorrekt Handhabung kann dieses Material Gesundheitsschäden verursachen. Siehe hierzu die Hinweise zur Handhabung im Service-Handbuch.

WARNING **Beryllium Kupfer**

In diesem Gerät sind einige mechanische Komponenten aus Beryllium Kupfer gefertigt. Dies ist eine Verbindung welche aus einem Berylliumanteil von ca. 5 % besteht. Bei normaler Verwendung besteht kein Gesundheitsrisiko.

Das Metall darf nicht bearbeitet, geschweißt oder sonstiger Wärmebehandlung ausgesetzt werden.

Es muß als Sondermüll entsorgt werden.

Es darf nicht durch Verbrennung entsorgt werden.

Precauzioni

WARNING

CAUTION

Note

Questi termini vengono utilizzati in questo manuale con significati specifici:

WARNING

riportano informazioni atte ad evitare possibili pericoli alla persona.

CAUTION

riportano informazioni per evitare possibili pericoli all'apparecchiatura.

Note

riportano importanti informazioni di carattere generale.

Simboli di pericolo

Significato dei simboli di pericolo utilizzati nell'apparato:

Simbolo

Tipo di pericolo



Pericolo generico



Pericolo sostanze tossiche

Condizioni generali d'uso

Questo prodotto è stato progettato e collaudato per rispondere ai requisiti della direttiva IEC/EN61010-1 'Safety requirements for electrical equipment for measurement, control and laboratory use' per apparati di classe III portatili e per l'uso in un ambiente inquinato di grado 2. L'apparato è stato progettato per essere alimentato da un alimentatore di categoria I.

Lo strumento deve essere protetto dal possibile ingresso di liquidi quali, ad es., acqua, pioggia, neve, ecc. Qualora lo strumento venga portato da un ambiente freddo ad uno caldo, è importante lasciare che la temperatura all'interno dello strumento si stabilizzi prima di alimentarlo per evitare formazione di condense. Lo strumento deve essere utilizzato esclusivamente nelle condizioni ambientali descritte nel capitolo 1 'Performance data' del manuale operativo, in caso contrario le protezioni previste nello strumento potrebbero risultare non sufficienti.

Questo prodotto non è stato approvato per essere usato in ambienti pericolosi o applicazioni medicali. Se lo strumento deve essere usato per applicazioni particolari collegate alla sicurezza (per esempio applicazioni militari o avioniche), occorre che una persona o un istituto competente ne certifichi l'uso.

WARNING



Pericoli da elettricità (alimentazione a c.c.)

Questo strumento rispetta le norme IEC, classe III, e quindi, per una completa sicurezza, deve essere collegato solo ad alimentatori e generatori di segnali che rispettano i requisiti di tensione ed isolamento SELV e SELV-E (Separated Extra-Low Voltage). Nessuna tensione pericolosa è generata al suo interno. Vedi capitolo 1 per quanto concerne i livelli massimi di tensione applicabili.

WARNING **Pericolo d'incendio**

L'accesso ai fusibili dell'alimentazione avviene attraverso la rimozione di un coperchio esterno. La rimozione dei coperchi dovrebbe essere eseguita solo da personale qualificato. Per una protezione costante contro pericoli d'incendio, utilizzare esclusivamente fusibili del tipo e dalle caratteristiche elettriche prescritte.

WARNING **Pericolo sostanze tossiche**

Alcuni dei componenti usati in questo strumento possono contenere resine o altri materiali che, se bruciati, possono emettere fumi tossici. Prendere quindi le opportune precauzioni nell'uso di tali parti.

WARNING **Berillio**

Berillio (ossido di berillio) è utilizzato nella costruzione di alcuni componenti di quest'apparato.

Questo materiale, se maneggiato non correttamente, può causare danni alla salute. Far riferimento ai capitoli di manutenzione del Manuale di Servizio per le precauzioni richieste.

WARNING **Rame berillio**

Alcuni componenti meccanici in questo strumento sono realizzati in rame berillio. Si tratta di una lega con contenuto di berillio di circa il 5%, che non presenta alcun rischio in usi normali.

Questo materiale non deve essere lavorato, saldato o subire qualsiasi processo che coinvolge alte temperature.

Deve essere eliminato come "rifiuto speciale". Non deve essere eliminato tramite "inceneritore".

Precauciones

WARNING

CAUTION

Note

Estos términos tienen significados específicos en este manual:

WARNING

contienen información referente a prevención de daños personales.

CAUTION



contienen información referente a prevención de daños en equipos.

Note

contienen información general importante.

Símbolos de peligro

Los significados de los símbolos de peligro que aparecen en los equipos son los siguientes:

Símbolo	Naturaleza del peligro
	Peligro general
	Aviso de toxicidad

Condiciones generales de uso

Este producto ha sido diseñado y probado para cumplir los requerimientos de la normativa IEC/EN61010-1 “Requerimientos de la normativa para equipos eléctricos de medida, control y uso en laboratorio”, para equipos clase III portátiles y para uso en un ambiente con un grado de contaminación 2. El equipo ha sido diseñado para funcionar sobre una instalación de alimentación de categorías II.

Debe protegerse el equipo de la entrada de líquidos y precipitaciones como nieve, lluvia, etc. Cuando se traslada el equipo de entorno frío a un entorno caliente, es importante aguardar la estabilización el equipo para evitar la condensación. Sólo debe utilizarse el aparato en las condiciones ambientales especificadas en el capítulo 1 “Especificaciones” o “Performance data” del Manual de Instrucciones/Manual de Operación/Funcionamiento, en caso contrario la propia protección del equipo puede resultar dañada.

Este producto no ha sido aprobado para su utilización en entornos peligrosos o en aplicaciones médicas. Si se va a utilizar el equipo en una aplicación con implicaciones en cuanto a seguridad, como por ejemplo aplicaciones de aviónica o militares, es preciso que un experto competente en materia de seguridad apruebe su uso.

WARNING



Nivel peligroso de electricidad (tensión de alimentación DC)

Este equipo cumple con la norma de seguridad IEC clase III, lo que significa que para total seguridad debe ser conectado a alimentaciones y fuentes de señal que cumplan los requerimientos de tensión y aislamiento “Tensión Separada Extra-Baja” (SELV y SELV-E). Ninguna tensión generada internamente implica riesgo para el operario.

En el capítulo 1 “Especificaciones” podrá encontrar los valores máximos permitidos que pueden aplicarse.

WARNING**Peligro de incendio**

El acceso a los fusibles de alimentación se lleva a cabo retirando la tapa exterior del equipo. La retirada de las tapas deberá efectuarla personal cualificado. Para asegurar protección continuada frente a incendios, los fusibles fundidos sólo deberán reemplazarse con aquellos del tipo y valores correctos.

WARNING**Aviso de toxicidad**

Alguno de los componentes utilizados en este equipo pudieran incluir resinas u otro tipo de materiales que al arder produjeran sustancias tóxicas. Por tanto, tome las debidas precauciones en la manipulación de esas piezas.

WARNING**Berilio**

Berilio (óxido de berilio) Este material es utilizado en la fabricación de alguno de los componentes de este equipo.

Si se manipulase incorrectamente podría causar daños a la salud - En la sección de mantenimiento y reparación encontrará normas de manejo de seguridad.

WARNING**Berilio-cobre**

Algunos componentes mecánicos contenidos en este instrumento incorporan berilio-cobre en su proceso de fabricación. Se trata de una aleación con un contenido aproximado de berilio del 5%, lo que no representa ningún riesgo durante su uso normal.

El material no debe ser manipulado, soldado, ni sometido a ningún proceso que implique la aplicación de calor.

Para su eliminación debe tratarse como un "residuo especial". El material NO DEBE eliminarse mediante incineración.

Chapter 1

GENERAL INFORMATION

Contents

Introduction	1-1
Main features	1-1
Performance data	1-3
Versions, options and accessories.....	1-6

Introduction

The 3271 is a C size, message-based VXI signal generator covering the frequency range 9 kHz to 2.4 GHz. The RF output can be modulated in amplitude, frequency or phase using internal or external signal sources. Additionally pulse modulation may be applied externally. An internal AF source is capable of generating simultaneous two-tone modulation. The 3271 is 2-slots wide and conforms to revisions 1.3 and 1.4 of the VXI specification.

Main features

Frequency selection

Carrier frequency resolution is 1 Hz across the band. A series of carrier frequencies can be stored in non-volatile memory for recall when required.

Output

RF output up to +25 dBm (uncalibrated above 1.2 GHz) can be set with a resolution of 0.1 dB over the entire range. Carrier output can be completely disabled.

An electronic trip protects the generator output against reverse power of up to 50 W. This prevents damage to output circuits when RF or DC power is accidentally applied to the RF OUT connector.

To facilitate testing of receiver squelch systems, an attenuator hold function allows control of the RF output without introducing RF level drop-outs from the step attenuator.

The RF output level can be offset by up to ± 5.0 dB to compensate for cable or switching losses, or to standardize a group of instrument.

The maximum RF output level can be set so as to protect sensitive devices connected to the RF OUTPUT socket.

Spectral purity

With an SSB phase noise performance of typically -121 dBc/Hz at 20 kHz offset from a 1 GHz carrier, this instrument can be used for both in-channel and adjacent channel receiver measurements.

Harmonically related signals and non-harmonics are better than -25 dBc and -60 dBc respectively.

Modulation

Comprehensive amplitude, frequency and phase modulations are available. Pulse modulation can be applied to the carrier from an external pulse source. The instrument also accepts one or two logic level inputs to produce a 2-level or 4-level FSK modulated output. An internal modulation oscillator is provided, having a frequency range of 0.01 Hz to 20 kHz. The oscillator is capable of generating one or two modulation tones simultaneously in one modulation channel. An independent BNC input on the

front panel allows external modulation signals to be combined with the internal signal(s). These sources can be combined to give a number of modulation modes. The pulse modulation can be used in combination with the other forms of modulation.

The frequency modulation range provides a 1 dB bandwidth of typically 100 kHz and provides FM deviation up to a maximum of 100 kHz. AC or DC coupled FM can be selected. Phase modulation is also available with a 10 kHz bandwidth up to a maximum of 10 radians.

Amplitude modulation with a 1 dB bandwidth of typically 30 kHz and with modulation depths of up to 99.9% is available with a resolution of 0.1%. Pulse modulation is available as standard with typical rise and fall times of less than 10 μ s and 40 dB on/off ratio.

The external input voltage required for 100% modulation is 1 V RMS (1.414 V peak). To accommodate other signal levels, Automatic Level Control (ALC) can be selected which provides correctly calibrated modulation for inputs between 0.75 and 1.25 V RMS. HI and LO indications are reported when the input level is outside the range of the ALC system.

Incrementing

All major parameters can be incremented or decremented in steps. If no step size is programmed for a parameter, the steps are preset to 1 kHz for carrier frequency, 1 kHz for modulation oscillator, 1 kHz for FM deviation, 1% for AM depth, 0.1 rad for Φ M and 1 dB for output level.

Frequency sweep

The sweep capability of the instrument allows comprehensive testing of systems. Sweeps may be logarithmic or linear. Four parameters are used to specify sweep: start, stop, step size and time per step, all of which can be programmed by the user. Sweep triggering can be programmed as single shot or continuous and can be initiated directly or on the detection of a trigger. The triggering signal may be from a back plane trigger, programmed or from a TTL/CMOS signal applied to the front panel TRIGGER INPUT.

Memory

The instrument provides both non-volatile and volatile memory for storing instrument settings. The non-volatile memory provides 100 instrument settings and 100 settings of carrier frequency only. The volatile memory (RAM) also provides 100 instrument settings. Any one of the non-volatile instrument settings can be selected as the power-up setting for the instrument.

Memory sequencing

A software facility allows sequences of stored instrument settings to be defined. The incrementing facilities can then be used to cycle through the settings using the VXI trigger facilities.

Memory protection

To prevent accidental change of the contents of the stored settings, individual memories or ranges of memories can be write-protected.

Triggers

Triggering the 3271 Signal Generator may be via the VXI TTL triggers (0 - 7), the trigger command, *TRG message or front panel input.

Calibration data

All alignment data is digitally derived. Realignment can be undertaken, without removing covers, by protected functions via the VXI interface.

Performance data

GENERAL DESCRIPTION

The 3271 is a synthesized VXI signal generator covering the frequency range 9 kHz to 2.4 GHz.

The RF output can be amplitude, frequency, phase or pulse modulated. An internal programmable AF source is capable of generating simultaneous two tone modulation. All functions can be controlled by an IEEE 488.2 message based interface.

CARRIER FREQUENCY

Range	9 kHz to 2.4 GHz.
Resolution	1 Hz.
Accuracy	Equal to the frequency standard accuracy.

RF OUTPUT

Range	-137 dBm to +25 dBm for carrier frequencies up to 1.2 GHz, -137 dBm to +19 dBm for carrier frequencies above 1.2 GHz. Maximum output is reduced by 5 dB when pulse modulation is selected and/or by up to 6 dB dependant upon set AM depth.
Resolution	0.1 dB
Accuracy	Over a temperature range of 17°C to 27°C: Below +7 dBm: ±0.8 dB to 1.2 GHz, ±1.6 dB to 2.4 GHz. Above +7 dBm: ±1 dB to 1.2 GHz, ±2 dB to 2.4 GHz. Temperature coefficient <±0.02 dB/°C to 1.2 GHz, and <±0.04 dB/°C to 2.4 GHz.
Attenuator hold	Inhibits operation of the step attenuator from the level at which the function is enabled. Usable for a level reduction of at least 10 dB. Typical accuracy ± 3 dB.
Output impedance	50 Ω SMA female connector to MIL 390123D. For output levels less than -5 dBm output VSWR is less than 1.3:1 for carrier frequencies up to 1.2 GHz and less than 1.5:1 for carrier frequencies up to 2.4 GHz.
Reverse power	Protected against the application of reverse power to the output connector for levels up to 50 W from 50 Ω or 25 W from a source VSWR of 5:1. Tripping of the reverse power protection circuit illuminates a front panel LED and raises an interrupt. The circuit can be reset either by an explicit command or by a device reset.

SPECTRAL PURITY

Harmonics	Typically better than -30 dBc for levels up to +7 dBm, typically better than -25 dBc for levels 6 dB below the maximum specified output.
Non-harmonics	Better than -70 dBc for carrier frequencies up to 1 GHz, better than -64 dBc for carrier frequencies above 1 GHz, better than -60 dBc for carrier frequencies above 2 GHz.
Residual FM	Less than 4.5 Hz RMS in a 300 Hz to 3.4 kHz bandwidth at a carrier frequency of 1 GHz. Residual FM (typical) <1 Hz at 249 MHz <2 Hz at 501 MHz <3 Hz at 1001 MHz <6 Hz at 2001 MHz
SSB phase noise	Better than -121 dBc/Hz at 20 kHz offset from a 470 MHz carrier. Typically -121 dBc/Hz at 20 kHz offset from a 1 GHz carrier.
RF leakage	Complies with VXIbus revision 1.3/1.4 specifications below 1 GHz.

GENERAL INFORMATION

MODULATION

FM, AM or phase modulation can be applied to the carrier from an internal or external modulation source. The internal modulation source is capable of generating two simultaneous signals into any one of the modulation channels. Internal and external modulation can be simultaneously enabled to produce combined amplitude and frequency (or phase) modulation. Pulse modulation can be applied to the carrier from an external pulse source. The pulse modulation can be used in combination with the other forms of modulation. 2 level or 4 level FSK modulation can be applied to the carrier using data from an external source.

FREQUENCY MODULATION

Deviation range	0 to 100 kHz.
Resolution	3 digits or 1 Hz.
Bandwidth (1 dB)	DC to 100 kHz (DC coupled), 10 Hz to 100 kHz (AC coupled), 20 Hz to 100 kHz (AC coupled with ALC).
Accuracy	±5% at 1 kHz modulation rate.
Carrier error	Less than 1% of the set frequency deviation when DC coupled.
Distortion	Less than 3% at 1 kHz rate for deviations up to 100 kHz. Typically 0.5% at 1 kHz rate for deviations up to 10 kHz.
Group delay:	Less than 5 µs to 100 kHz.

FSK

Modes:	2 level or 4 level FSK.
Data source:	External data connected to TRIGGER INPUT connector (2 level) or TRIGGER INPUT and PULSE INPUT connectors (4 level).
Frequency shift:	Settable up to ±100 kHz.
Accuracy:	As FM deviation accuracy.
Timing jitter:	±3.2 µs
Filter:	8 th order Bessel, -3 dB at 20 kHz.

PHASE MODULATION

Range	0 to 10 radians.
Resolution	3 digits or 0.01 radians.
Bandwidth (3 dB)	100 Hz to 10 kHz.
Accuracy	±5% at 1 kHz modulation rate.
Distortion	Less than 3% at 10 radians at 1 kHz. Typically 0.5% for deviations up to 1 radian at 1 kHz.

AMPLITUDE MODULATION (for carrier frequencies <500 MHz, usable to 2 GHz)

Range	0 to 99.9%.
Bandwidth (1 dB)	DC to 30 kHz (DC coupled), 10 Hz to 30 kHz (AC coupled), 20 Hz to 30 kHz (AC coupled with ALC).
Resolution	0.1%.
Accuracy	±5% of set depth at 1 kHz rate at +17°C to 27°C ambient temperature. Temperature coefficient <0.02% per °C.
Distortion	Less than 2.5% at 1 kHz rate for modulation depths up to 80%, Less than 1.5% at 1 kHz rate for modulation depths up to 30%.
ΦM on AM	Typically 0.1 radians at 30% depth at 470 MHz.

PULSE MODULATION

Carrier frequency range	32 MHz to 2.4 GHz, usable to 10 MHz.
RF level range	Maximum guaranteed output is reduced to +20 dBm up to 1.2 GHz or +14 dBm above 1.2 GHz when pulse modulation is selected.
RF level accuracy	Maximum additional uncertainty is ± 0.5 dB.
Input	Front panel BNC connector with an input impedance of 10 k Ω nominal. A logical '1' (3.5 V to 5 V) turns the carrier on, a logical '0' (0 V to 1 V) turns the carrier off. Maximum safe input is ± 15 V.
ON/OFF ratio	Better than 40 dB, better than 45 dB below 1.2 GHz.
Rise and fall time	Less than 10 μ s.
Overshoot	Less than 1 dB.

MODULATION OSCILLATOR

The internal modulation oscillator is capable of generating one or two modulation tones simultaneously in one modulation channel.

Frequency range	0.01 Hz to 20 kHz.
Resolution	0.01 Hz to 100 Hz, 0.1 Hz to 1 kHz, and 1 Hz to 20 kHz.
Distortion	Less than 0.1% at 1 kHz.
Sine wave frequency response	Typically 1 dB DC to 20 kHz.
Waveforms	Sine to 20 kHz, triangle or square wave to 3 kHz. Square wave jitter <6.4 μ s on any edge.
Output	The modulation oscillator signal is available on a front panel BNC connector at a level of 2 V RMS EMF from a 600 Ω source impedance.

EXTERNAL MODULATION INPUT

A front panel BNC connector is provided for external modulation input.

Input level	1 V RMS (1.414 V peak) sine wave for set deviation. Maximum safe input is ± 15 V.
Input impedance	100 k Ω nominal.
Modulation ALC	Levels the applied external modulation over the range 0.75 to 1.25 V RMS.

SWEEP MODE

A carrier frequency sweep mode is provided. The sweep is defined by setting the start, stop and frequency step size. The step time can be set from 50 ms to 10 s per step. A step or the complete sweep may be triggered by the trigger input on the front panel, VXI backplane trigger, message or VXI command. Sweep can be set to continuous.

FREQUENCY STANDARD

The carrier frequency and internal modulation frequency are synthesized from either an internal reference oscillator or to an external reference.

Internal standard	10 MHz TCXO.
Aging rate	Less than ± 1 in 10^6 per year.
Temperature stability	Better than ± 5 in 10^7 over the temperature range 0 to 55°C.
External standard	Input: Requires an input of 220 mV RMS to 1.8 V RMS into 1 k Ω on front panel BNC connector. Input frequency can be 1 MHz or 10 MHz. Output: Front panel BNC socket provides an output of 10 MHz at a nominal level of 2 V pk-pk into 50 Ω .

CALIBRATION INTERVAL

Recommended 2 years. Realignment is accomplished by remote control. There are no mechanical adjustments required for realignment.

GENERAL INFORMATION

VXIbus INTERFACE CAPABILITIES	Complies with revision 1.3/1.4 of VXIbus specification for message based instruments.																		
Logical address	Manual selection (1 - 254).																		
Device type	Message based servant, programmable interrupter.																		
Protocol	Word serial IEEE 488.2. Fast handshake is not supported.																		
Address/Data	A16/D16.																		
Connectors	P1, P2 (highest slot of a 2 slot allocation).																		
TTLTRG	Can be used to sequence memories or trigger sweep.																		
CLK10	Not used.																		
Local bus	Not used.																		
ECLTRG	Not used.																		
Peak current & power consumption	<table><thead><tr><th></th><th>+24 V:</th><th>+12 V:</th><th>+5 V:</th><th>-12 V:</th><th>Total power:</th></tr></thead><tbody><tr><td>lpm</td><td>1.2 A</td><td>1.0 A</td><td>2.0 A</td><td>0.6 A</td><td>58 W max.</td></tr><tr><td>ldm</td><td>0.1 A</td><td>0.1 A</td><td>1.3 A</td><td>0.1 A</td><td></td></tr></tbody></table>		+24 V:	+12 V:	+5 V:	-12 V:	Total power:	lpm	1.2 A	1.0 A	2.0 A	0.6 A	58 W max.	ldm	0.1 A	0.1 A	1.3 A	0.1 A	
	+24 V:	+12 V:	+5 V:	-12 V:	Total power:														
lpm	1.2 A	1.0 A	2.0 A	0.6 A	58 W max.														
ldm	0.1 A	0.1 A	1.3 A	0.1 A															
Cooling (per slot)	2.4 litre/s at 0.5 mm H ₂ O backpressure for 10°C maximum temperature rise.																		
Front panel indicators	LEDs on module's front panel indicate POWER OK (green), SYSTEM FAIL (red) and RPP TRIP - Reverse Power Protection Tripped (red).																		
MTBF	Greater than 10,000 hours to MIL 217F.																		
ELECTROMAGNETIC COMPATIBILITY	Complies with VXIbus revision 1.3/1.4 for specifications below 1 GHz. Conforms to the protection requirements of Council Directive 89/336/EEC. Complies with the limits specified in the following standards: EN55011 Class B CISPR 11 EN50082-1 IEC 801-2, 3, 4																		
SAFETY	This instrument is designed to comply with the requirements of EN61010-1/IEC1010-1, for Class III portable equipment and is for use in a pollution degree 2 environment. The equipment is designed to operate from an installation category 1 supply.																		
RATED RANGE OF USE	Specification is met over the temperature range 0 to +55°C, humidity up to 93% at 40°C and elevation up to 3050 m (10,000 ft).																		
CONDITIONS OF STORAGE AND TRANSPORT	The instrument can be stored at temperatures from -40°C to +71°C, elevations up to 4600 m and humidities up to 95% at 40°C.																		
DIMENSIONS AND WEIGHT																			
Dimensions	2 slot, C size.																		
Weight	Less than 4 kg.																		

Versions, options and accessories

When ordering please quote the full ordering number information.

Ordering numbers

3271

A8130
60-0042

Versions

9 kHz to 2.4 GHz Signal Generator.

Supplied accessories

Operating manual (this manual).
3271 VXI plug & play Install Disk
(software version 3.11).

CE

CE CONFORMITY

EC Directives 73/23/EEC, 89/336/EEC, 92/31/EEC and 93/68/EEC.

Units that carry the CE mark are designed to conform to standards, EN 61010-1, EN 55011, EN 50082-1, when used in accordance with these instructions.

SAFETY

Always operate the product in accordance with the instructions in this manual.

EMC

To ensure that EMC integrity is retained always follow good EMC practice. In particular:

- (1) Use good quality coaxial connections for signal input and output leads.
- (2) Use good quality screened data or control cables and connectors.
- (3) Ensure that cable screens are properly terminated within the connectors. Do not use cables if the terminations are loose or frayed.
- (4) Ensure that the screening is continuous through to the chassis of the equipment.
- (5) Ensure that any associated equipment is CE marked or is of good EMC design and performance.

RACAL Instruments Ltd.

Chapter 2

INSTALLATION AND POWER-UP

Contents

Initial visual inspection.....	2-1
Setting logical address	2-1
Ventilation requirements.....	2-1
Installing in VXI mainframe	2-2
Routine safety testing and inspection.....	2-2
Internal fuses.....	2-2
Cleaning.....	2-2
Putting into storage.....	2-3
Front panel connectors and indicators	2-3
Switching on	2-4
Disk installation/loading instructions.....	2-4

List of figures

Fig. 2-1 3271 front panel showing connectors and indicators	2-3
---	-----

Initial visual inspection

Immediately after unpacking thoroughly inspect the instrument for signs of physical damage that may have occurred during shipping. If any damage is found, return the instrument to your supplier's address.

Attach a label indicating the service required, type or model number, serial number and your return address. Use the container and packing materials that were used to ship the instrument.

Setting logical address

Before installing the signal generator in the VXI mainframe, verify that the logical address is between 1 and 254 and does not clash with the logical address of any other device in the rack. The logical address is set on a bank of 8 DIL switches. These are located on the right-hand side of the instrument. Use some form of stylus (e.g. a ball-point pen) to move the switches to form the binary address. Logical addresses may be set in the range 1 to 254. Logical address 0 is reserved for slot 0 devices and logical address 255 is reserved for dynamically configured devices. The 3271 VXI Signal Generator does not support dynamic configuration.

Ventilation requirements

Ensure that the VXI signal generator module is supplied with adequate cooling i.e. 2.4 litre/s at 0.5 mm H₂O backpressure minimum per slot.

Installing in VXI mainframe

This instrument will take up two slots of a C-sized VXI mainframe. Before installation ensure that the mainframe power is off. To install the instrument first set the logical address (see 'Setting logical address' above), if required, then slide the module into the mainframe ensuring that the top and bottom card guides are in the slots. Ensure that the rear connectors are seated properly and screw in the front panel retaining screws. The instrument is now ready to power up.

CAUTION

Never insert or remove the instrument when the mainframe is already powered up.

Routine safety testing and inspection

In the UK the 'Electricity at Work Regulations' (1989) section 4(2) places a requirement on the users of equipment to maintain it in a safe condition. The explanatory notes call for regular inspections and tests together with a need to keep records.

This module is not designed to be connected to a supply or signals which present hazardous levels, and no hazardous voltages are generated internally. All such levels must be maintained within 'Separated Extra-Low Voltage' (SELV or SELV-E) limits for continued safety. No requirement therefore exists to carry out insulation tests on the module. Periodic electrical tests and visual inspections should however be performed on the complete mainframe/chassis by competent personnel. Information should be sought from the mainframe supplier regarding the visual inspection, earth bonding and insulation resistance test requirements.

Visually check that the module has been installed in accordance with the instructions provided (e.g. that the ventilation is adequate, all fixing screws are present and tightened, and that all warning labels, markings and supplied safety information are present and legible). If any defect is noted this should be rectified before proceeding with further electrical tests.

No attempt should be made to perform high current earth bonding tests on the functional earths (e.g. signal carrying connector shells or screen connections) present on the module connectors. High current earth bonding tests are also not recommended between the mainframe protective earth connector and the module front panel. Serious damage may result to both the module and the mainframe if the module is not fully screwed into the mainframe during high current testing. Low current earth bonding tests (1 mA to 100 mA) should be performed to establish earth path continuity between the module front panel and the mainframe protective earth.

Internal fuses

Note that there are non-operator replaceable, internal, fuses fitted on Control Board AB2. These are as follows:

Circuit designator	Type & value	Supply fused
FS1	F2A	+24 V
FS2	F2A	+24 V
FS3	F1A	-12 V
FS4	F3.15A	+5 V

Cleaning

Cleaning is restricted to wiping the front panel occasionally with a dry, lint-free cloth.

Putting into storage

If the instrument is to be put into storage, ensure that the following conditions are maintained:

Temperature range: -40 to +70°C
 Humidity: Less than 93% at 40°C

Front panel connectors and indicators

The front panel with its connectors and indicators is shown in Fig. 2-1 below:

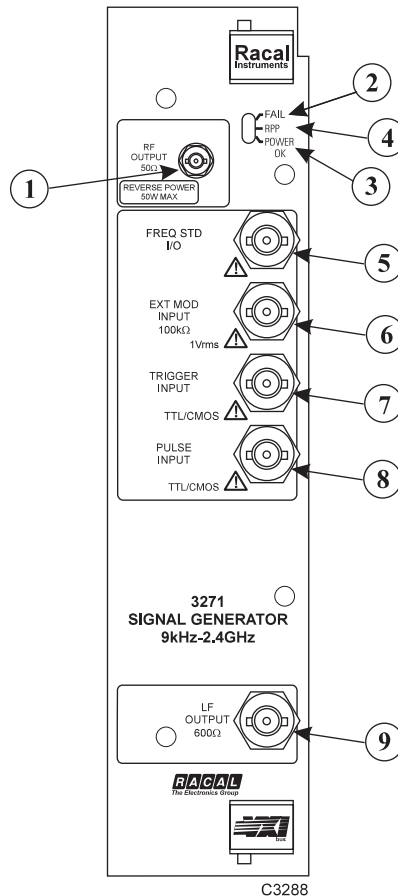

Fig. 2-1 3271 front panel showing connectors and indicators

- | | | |
|---|---------------------|---|
| ① | RF OUTPUT | 50 Ω SMA-type socket. Protected against the application of reverse power of up to 50 W. |
| ② | SYSTEM FAIL | This red LED lights to indicate that the signal generator has failed, or is in the process of executing its self-test. It indicates the condition of the VXI-bus SYSFAIL line. The LED will continue to be lit whilst the self-test is in progress even when SYSFAIL is inhibited by the commander. |
| ③ | POWER OK | This green LED lights to indicate that power is being supplied to the signal generator. All lines are continuously checked for sufficient voltage. |
| ④ | RPP TRIP | This red LED lights to indicate that the Reverse Power Protection (RPP) circuit has tripped. The power source must be removed from the RF OUTPUT socket. |
| ⑤ | FREQ STD I/O | BNC socket for the input of external standard frequencies of either 1 MHz or 10 MHz. Also supplies a 10 MHz internal standard output. |

- ⑥ **EXT MOD INPUT** BNC socket which allows an external modulating signal to be applied.
- ⑦ **TRIGGER INPUT** BNC socket which has three uses; in priority order these are:
 - FSK logic input
 - Memory sequencing
 - Sweep trigger.
- ⑧ **PULSE INPUT** 10 k Ω BNC socket which accepts a pulsed input. Also used as one logic input (the other is the TRIGGER INPUT) for 4FSK modulation.
- ⑨ **LF OUTPUT** 600 Ω BNC socket which monitors the modulation oscillator.

Switching on

Insert the signal generator module in the required slot in the mainframe and screw in the retaining screws. Switch the mainframe on. All three LEDs should initially light while the generator carries out its self checks. When the unit passes its self checks, and if there are no errors detected on the backplane, the red SYSTEM FAIL and RPP LEDs will go out within 5 seconds and the green POWER OK LED will remain on.

Disk installation/loading instructions

The 3271 VXI plug & play Install Disk is supplied with this instrument. This includes the VXI plug & play instrument driver and soft front panel. The soft front panel is used to verify instrument communications and functionality when the instrument is first integrated into a system. Before inserting the disk in your drive read the installation or loading instructions given on the label of the disk. Refer to 'read me' files for further information.

Chapter 3 PROGRAMMING

Contents

Introduction	3-3
Device listening elements	3-3
Device talking elements.....	3-3
Programming	3-4
Program messages	3-4
Compound headers	3-4
Program data.....	3-5
Message exchange protocol.....	3-5
Common commands and queries (IEEE 488.2).....	3-5
Device dependent commands	3-6
Default settings	3-7
Carrier frequency	3-9
RF level	3-10
Output control.....	3-12
Modulation mode.....	3-13
Modulation control	3-14
Frequency modulation (and FSK).....	3-15
Phase modulation.....	3-17
Amplitude modulation	3-19
Pulse modulation	3-21
Memory stores	3-22
Memory - store	3-22
Memory-recall	3-23
Recalling default settings.....	3-23
Memory - erase.....	3-24
Memory - sequencing	3-24
Memory - triggering.....	3-25
Memory - protection.....	3-25
Sweep operation	3-26
Sweep mode.....	3-27
Sweep control	3-28
Trigger source.....	3-29
Sources	3-29
Miscellaneous commands	3-30
Attenuator hold	3-30
Power-up options.....	3-31
Reverse power protection	3-32
Operating hours	3-32
Frequency standard selection.....	3-33
Reading error messages	3-33
Status byte	3-34
Status data structure - register model.....	3-35
Standard event registers.....	3-36
Hardware event registers	3-37
Coupling event registers	3-38
Instrument event registers	3-39
Queue flag details	3-40
Status byte when read by *STB?	3-41

Contents (*contd.*)

Status byte when read by serial poll	3-42
Summary of status reporting commands and queries	3-43
Error messages	3-44
Error handling	3-44
Background errors:.....	3-44
Foreground errors:	3-44
Error queue	3-44

List of tables

Table 3-1 Instrument default settings	3-7
Table 3-2 Attenuator lock ranges	3-30
Table 3-3 Background errors (500 - 599) in priority order	3-45
Table 3-4 Foreground errors (0 - 399)	3-46
Table 3-5 IEEE 488.2 errors (400 - 499)	3-47

Introduction

An IEEE 488.2 program interface is provided. Ease of use is ensured by careful selection of mnemonics. For example, if carrier frequency and RF level are to be set to 2.54 MHz and -27.3 dBm respectively, the VXI instruction message is:

```
CFRQ:VALUE 2.54 MHZ<EOM>
RFLV:VALUE -27.3 DBM<EOM>
```

For full information on the IEEE protocols and syntax the IEEE 488.2 standard should be consulted.

Device listening elements

The following is a list of the device listening elements (as defined in the IEEE 488.2 standard) which are used in the instrument:

```
<PROGRAM MESSAGE>
<PROGRAM MESSAGE TERMINATOR>
<PROGRAM MESSAGE UNIT>
<PROGRAM MESSAGE UNIT SEPARATOR>
<COMMAND MESSAGE UNIT>
<QUERY MESSAGE UNIT>
<COMPOUND COMMAND PROGRAM HEADER>
<COMPOUND QUERY PROGRAM HEADER>
<PROGRAM HEADER SEPARATOR>
<PROGRAM DATA>
<PROGRAM DATA SEPARATOR>
<DECIMAL NUMERIC PROGRAM DATA>
<CHARACTER PROGRAM DATA>
<SUFFIX PROGRAM DATA>
<STRING PROGRAM DATA>
<ARBITRARY BLOCK PROGRAM DATA>
```

Device talking elements

The following is a list of the device talking elements (as defined in the IEEE 488.2 standard) which are used in the instrument:

```
<RESPONSE MESSAGE>
<RESPONSE MESSAGE TERMINATOR>
<RESPONSE MESSAGE UNIT>
<RESPONSE MESSAGE UNIT SEPARATOR>
<COMPOUND RESPONSE HEADER>
<RESPONSE HEADER SEPARATOR>
<RESPONSE DATA>
<RESPONSE DATA SEPARATOR>
<NR1 NUMERIC RESPONSE DATA>
<NR2 NUMERIC RESPONSE DATA>
<ARBITRARY ASCII RESPONSE DATA>
<CHARACTER RESPONSE DATA>
<STRING RESPONSE DATA>
<DEFINITE LENGTH ARBITRARY BLOCK RESPONSE DATA>
```

Programming

Program messages

A message consists of one or more message units. Message units are separated by a semi-colon (;). The whole message is ended by the Program Message Terminator (or End Of Message) defined as one of the following:

- (1) <newline> (ASCII 10 - often known as 'line feed') or
- (2) <newline> + END (the EOI line is asserted as well) or
- (3) + END (EOI is asserted in the last data byte of the message)

Note

A response message is always terminated by <EOM> consisting of <newline> + END.

A message unit consists of a mnemonic header which may be followed by data. If data follows, then it must be separated from its header by at least one space:

<header><SPACE><data>

e.g. RFLV:INC 6.0 dB

Spaces may be freely inserted in a message to improve readability, except within a header or within data.

A header may be a command or a query. A query has a '?' as its final character and causes the generation of a response message which will be read by the controller. Common commands and queries (defined in IEEE 488.2) begin with a '*':

Upper and lower case characters are considered equivalent (i.e. FM fm Fm fM are all interpreted by the instrument in the same way).

Compound headers

The instrument implements compound headers which allows a complex set of commands to be built up from a small set of basic elements in a 'tree and branch' structure. The elements of a compound header are separated by a colon (:). Spaces are not allowed within a header.

Special rules apply when more than one compound header is used in one message. When the separator ';' is encountered, all headers except the trailing element of the previous header in the message are assumed to precede the following header, for example:

AM:DEPTH 30PCT;ON

is equivalent to the two commands:

AM:DEPTH 30PCT

and AM:ON

This does not apply to common commands (*RST etc.). The rule may be overridden by preceding a header with a colon, for example:

AM:ON;;FM:ON

Most main functions have a short form of header which may be used for clarity and brevity in simple messages, for example:

CFRQ 1.25GHZ is the same as CFRQ:VALUE 1.25GHZ

Program data

Data can take many forms, as follows:

Decimal Numeric Data is a flexible numeric format which encompasses integer, fixed point and floating point (mantissa and exponent) representations. Data is rounded to a resolution appropriate to the function. Decimal data can, in most cases, be followed by the appropriate units. If no units are present, the specified default units are assumed.

Character Data is an alphanumeric word.

String Data consists of a number of 7-bit ASCII characters enclosed in quotes, either a pair of single ('ASCII 39') or double ("ASCII 34") quotes may be used.

Some commands can accept Multiple Data items which are separated by commas, for example MODE FM,AM.

Message exchange protocol

The controller should not attempt to read a response until it has sent the entire query message (terminated by EOM). Also, it should not start to send a new message until it has read the entire response (terminated by EOM). The query message may contain more than one query message unit, but only one response message (containing several response message units) is generated.

Failure to follow the protocol will generate a query error:

INTERRUPTED (error 450) occurs when the controller starts to send a new message before having read the response to a preceding query.

UNTERMINATED (error 451) occurs when the controller attempts to read a response without having sent a query.

DEADLOCK (error 452) can only occur if the input and output buffers are both filled by the controller having sent an extra long message containing several query message units.

These instruments have an input buffer of 256 characters and an output buffer of 256 characters.

Common commands and queries (IEEE 488.2)

The IEEE 488.2 standard defines a set of common commands and queries which implement common system functions.

Common command and query mnemonics are preceded by an asterisk (*) to distinguish them from device dependent data such as instrument programming strings. The following common commands and queries are implemented in the instrument:

Mnemonic	Name and Description
*IDN?	<p>Identification Query. Returns an arbitrary ASCII response comprising four data fields in the format:</p> <p><manufacturer>,<model>,<serial number>,<software part number and issue number></p> <p>where: <manufacture> is RACAL INSTRUMENTS,<model> is the instrument model number, 3271.</p> <p><serial number> is the instrument serial number in the form nnnnnn/nnn, where n is an ASCII digit in the range 0 to 9.</p> <p><software part number and issue number> is in the form nnnnn/nnn/n.nn, where n is an ASCII digit in the range 0 to 9.</p> <p>Example: RACAL INSTRUMENTS, 3271, 811152/011, 44533/445/01.00<EOM></p>
*OPT?	<p>Option Identification Query. Returns an arbitrary ASCII response containing a data field for each fitted option in the format:</p> <p><option a>,<option b>, ... ,<option n><EOM></p> <p>If no options are fitted, ASCII '0' is returned.</p>

Note

Because an Arbitrary ASCII Response ends with the Response Message Terminator (<EOM>) either *IDN? or *OPT? must be the last Query Message Unit in a Program Message.

*RST	Reset Command. Sets the instrument functions to the factory default power up state.
*TST?	Self Test Query. Returns a '0' when the VXI interface and processor are operating.
*OPC	Operation Complete Command. Sets the Operation Complete bit in the Standard Event Status Register when execution of the preceding operation is complete.
*OPC?	Operation Complete Query. Returns a '1' when the preceding operation has been completed.
*WAI	Wait to Continue Command. Inhibits execution of an overlapped command until the execution of the preceding operation has been completed.
*TRG	Trigger Command. Equivalent to Group Execute Trigger.
*STB?	Read Status Byte Query. Returns the value of the Status Byte as an nr1 number (0-255).
*SRE <nrf>	Service Request Enable Command. Sets the Service Request Enable Register.
*SRE?	Service Request Enable Query. Returns the value of the Service Request Enable Register as nr1.
*ESR?	Standard Event Status Register Query. Returns the value of the Status Event Status Register as nr1.
*ESE <nrf>	Standard Event Status Enable Command. Sets the Standard Event Enable Register.
*ESE?	Standard Event Status Enable Query. Returns the value of the Standard Event Status Enable Register as nr1.
*CLS	Clear Status Command. Clears all the Status Event registers and clears the Error Queue. Does not affect the Enable Registers.

Note

The IEEE 488.2 Device Clear function only affects the remote functions. The input and output buffers are cleared and the instrument put into a state to accept new messages. Earlier versions of IEEE 488.1 put the instrument functions into a defined state, but this is now performed by the *RST common command.

Device dependent commands

The following list describes the features of the device dependent mnemonics for the instrument together with simple examples of their use within each major section (Carrier frequency, RF level, etc.) The root mnemonic is listed first followed by the lower level mnemonics. Each group is followed by a list of requirements for data type and suffix.

In addition to the normal listen commands the instrument accepts query commands which cause it to prepare a message which will be sent to the controller when the instrument is next addressed to talk. For each query an example of a response is given. Where responses are similar for a group of queries not all are listed. Some queries can produce more than one type of response - an example of each is usually given.

In the list which follows, the abbreviations <char>, <nrf> and <str> have the following meanings:

<char>	=	Character Program Data
<nrf>	=	Decimal Numeric Program Data

<str> = String Program Data

Where the data format is Decimal Numeric Program Data, the value may be expressed as a signed or unsigned number in any of the following formats:

- nr1: Decimal integer, e.g. 1234 or -567
- nr2: Floating point number, e.g. 1.234 or -56.789
- nr3: Floating point number with exponent, e.g. 1.2345E5 or -12.47E-8

Default settings

The instrument is reset to the factory default settings in the following cases:

- (1) At power-up.
- (2) Following execution of the RCL 999 command.
- (3) Following execution of the *RST command.

The default settings are shown in Table 3-1 .

Table 3-1 Instrument default settings

Carrier frequency	:	2.4 GHz
Step	:	1 kHz
RF level	:	-137 dBm
Step	:	1 dB
Status	:	ON
RF output	:	Enabled
Modulation mode	:	Internal FM, modulation disabled
Modulations	:	FM1 : Deviation: 0 Hz, OFF : Internal source, frequency: 1 kHz, sine
	:	FM2 : Deviation: 0 Hz, OFF : Internal source, frequency: 400 Hz, sine
	:	Φ M1 : Deviation: 0 rad, OFF : Internal source, frequency: 1 kHz, sine
	:	Φ M2 : Deviation: 0 rad, OFF : Internal source, frequency: 400 Hz, sine
	:	AM1 : Deviation: 0%, OFF : Internal source, frequency: 1 kHz, sine
	:	AM2 : Deviation: 0%, OFF : Internal source, frequency: 400 Hz, sine
	:	Pulse : OFF
Modulation steps	:	Δ FM 1 kHz, $\Delta\Phi$ M 0.1 rad, Δ AM 1%
Mod frequency steps	:	10 Hz

Carrier sweep:	
Freq mode:	Fixed
Mode :	Single sweep
Type:	Linear
Ext trigger :	OFF
Start :	9 kHz
Stop:	2.4 GHz
Step size:	1 kHz
Time:	50 ms

Carrier frequency

These commands enable you to set the carrier frequency in the range 9 kHz to 2.4 GHz to a resolution of 1 Hz. You can adjust the frequency in steps by setting the size of the step and then stepping the frequency up or down. After having adjusted the frequency you can either return to the reference frequency or make the current frequency the reference frequency. Additionally, you can adjust the phase offset of the carrier in degrees in the range -359.99° to $+359.99^\circ$. Also you can configure the instrument as a swept frequency signal generator where you define the start and stop frequencies and set the step size, step time and step direction. For triggering methods, refer to 'Trigger source' at the end of this section.

CFRQ	Set Carrier Frequency (short form)
:VALUE	Set Carrier Frequency
:INC	Set Carrier Frequency step size
	Data type : Decimal Numeric Program Data
	Allowed suffices : Any one of: GHZ, MHZ, KHZ or HZ
	Default suffix : HZ
:UP	Go UP one step
:DN	Go DOWN one step
:RETN	Return to original setting
:XFER	Transfer current value to be the new setting
	Data type : None
	Allowed suffices : None
	Default suffix : None
:MODE	Selects the mode of carrier frequency operation. SWEPT enables swept carrier frequency operation, while FIXED disables it
	Data type : Character Program Data (FIXED - non swept mode, SWEPT - swept mode)
	Allowed suffices : None
	Default suffix : None
:START	Set Start Frequency for use in sweep
:STOP	Set Stop Frequency for use in sweep
	Data type : Decimal Numeric Program Data
	Allowed suffices : Any one of: GHZ, MHZ, KHZ or HZ
	Default suffix : HZ
:TIME	Set time per sweep step
	Data type : Decimal Numeric Program Data
	Allowed suffices : MS or S
	Default suffix : MS
:PHASE	Adjust Phase Offset of Carrier in degrees
	Data type : Decimal Numeric Program Data
	Allowed suffices : DEG
	Default suffix : DEG
	Examples: CFRQ:VALUE 2.54MHZ;INC 10KHZ CFRQ:UP;XFER CFRQ:START 1MHZ;STOP 10MHZ;TIME 100MS CFRQ:MODE SWEPT
CFRQ?	Prepares message containing information on Carrier Frequency setting in the following format:
	:CFRQ:VALUE <nr2>; INC <nr2>;MODE<mode>
	where: <mode> is character program data indicating whether carrier frequency operation is swept or fixed
	Example: :CFRQ:VALUE 100000000.0;INC 25000.0;MODE FIXED

RF level

These commands enable you to set the RF level in the range -137 to +25 dBm to a resolution of 0.1 dB. You can adjust the level in steps by setting the size of the step and then stepping the level up or down. And after having adjusted the level you can either return to the reference level or make the current level the reference level. You can set the units to a default if required. For voltage related units, you can select either EMF or PD. You can also switch the output at the RF OUT socket off or on. For attenuator hold see under 'Miscellaneous commands' below.

You can also set your own maximum output power limit which allows you to protect sensitive devices connected to the RF OUTPUT socket. The maximum calibrated output level is +25.1 dBm up to 1.2 GHz and +19 dBm above this frequency. Above 1.2 GHz an uncalibrated level up to +25.1 dBm is allowed. The setting will be saved in non-volatile memory so that when subsequently the instrument is switched on again it will be set with your specified RF level limit.

The RF offset function enables you to offset the RF output level to compensate for cable or switching losses, or to standardize a group of instruments so that they give identical measurements. One offset is allowed in each of the following ranges:

9 kHz	-	150 MHz
150 MHz	-	300 MHz
300 MHz	-	600 MHz
600 MHz	-	1.2 GHz
1.2 GHz	-	2.4 GHz

The entered carrier frequency automatically selects the appropriate frequency range over which the offset is applied. Set the required positive or negative RF offset in the range 0 to 5.0 dB to a resolution of 0.1 dB. For each required additional range enter the carrier frequency then the offset. Ensure that your offsets are saved so that when subsequently the instrument is switched on again it will be set with your specified offsets.

RFLV	Set RF Output Level (short form)
:VALUE	Set RF Output Level
	Data type : Decimal Numeric Program Data
	Allowed suffices : Any one of: DBM, DBV, DBMV, DBUV, V, MV or UV
	Default suffix : DBM unless changed by UNITS command
:INC	Set RF Level step (dB)
	Data type : Decimal Numeric Program Data
	Allowed suffices : DB only
	Default suffix : DB
:UP	Go UP one step
:DN	Go DOWN one step
:RETN	Return to original setting
:XFER	Transfer current value to be the new setting
:ON	Turn RF Output ON
:OFF	Turn RF Output OFF
	Data type : None
	Allowed suffices : None
	Default suffix : None
:TYPE	Selects EMF or PD for voltage related units
	Data type : Character Program Data (EMF or PD)
	Allowed suffices : None
	Default suffix : None

RFLV (contd.)

:UNITS Select default RF level units.

Data type : Character Program Data (DBM, DBV, DBMV, DBUV, V, MV or UV)
 Allowed suffices : None
 Default suffix : None

Examples: RFLV:VALUE -27.3DBM;ON
 RFLV:TYPE PD;VALUE 1.23UV

:LIMIT Set RF Level max limit (short form)

:VALUE Set RF Level max limit

Data type : Decimal Numeric Program Data
 Allowed suffices : Any one of: DBM, DBV, DBMV, DBUV, V, MV or UV
 Default suffix : DBM unless changed by UNITS command

:ENABLE Enable limit

:DISABLE Disable limit

:OFFS Set RF Level offset for given frequency band (short form)

:VALUE Set RF Level offset for given frequency band

Data type : Decimal Numeric Program Data
 Allowed suffices : DB only
 Default suffix : DB

:ENABLE Enable offsets

:DISABLE Disable offsets

:SAVE Save offsets in non-volatile memory

RFLV?

Prepares message containing information on RF Level setting in the following format:

:RFLV:UNITS <unit>;TYPE <type>;VALUE <nr2>;INC
 <nr2>;<status>

where: <unit> is character program data defining the default RF level units (DBM, DBV, DBMV, DBUV, V, MV or UV), <type> is character program data indicating EMF or PD and <status> is a program mnemonic indicating whether the RF output is ON or OFF

Examples: :RFLV:UNITS DBM;TYPE PD;VALUE -103.5;INC 2.0;ON
 :RFLV:UNITS DBV;TYPE EMF;VALUE -83.2;INC 0.5;ON

RFLV:LIMIT?

Prepares message containing information on RF Level max limit setting in the following format:

:RFLV:LIMIT:VALUE<nr2>;<status>;

Example: :RFLV:LIMIT:VALUE-20.0;ENABLE

RFLV:OFFS?

Prepares message containing information on RF Level offset in the following format:

:RFLV:OFFS:VALUE<nr2>;<status>;

Example: :RFLV:OFFS:VALUE-3.2;ENABLE

Output control

These commands allow you to download and store settings without the output changing.

OUTPUT

[not used alone]

:DISABLE

Allows user to download and store settings in the normal way without the output of the instrument changing until the OUTPUT:ENABLE command is received.

:ENABLE

Enables the instrument outputs such that the outputs will adjust to the values specified by commands sent while the outputs were disabled.

Note: It is up to the user to ensure that the last command sent, prior to OUTPUT:ENABLE, is such that the RF output is set to a safe level.

Data type : None

Allowed suffices : None

Default suffix : None

Examples:

```
OUTPUT:DISABLE
CFRQ 300MHZ; RFLV 10DBM; MODE AM; AM 40PCT;
AM:ON; MOD:ON; STO 200
CFRQ 400MHZ; RFLV 7DBM; STO 201
CFRQ 500MHZ; RFLV 5DBM; STO 202
CFRQ 600MHZ; RFLV 4DBM; STO 203
OUTPUT:ENABLE
RCL 200
RCL 201
RCL 202
RCL 203
```

OUTPUT?

Prepares message containing information on output control setting in the following format:

: OUTPUT: <status>

where: <status> is a program mnemonic indicating whether the output control is ENABLED or DISABLED

Examples:

```
:OUTPUT:ENABLE
:OUTPUT:DISABLE
```

Modulation mode

These commands allow you to select the modulation mode between amplitude, frequency and phase modulation as well as binary (2-level) and quadrature (4-level) frequency shift keying. Binary FSK results from a logic level digital signal applied to the TRIGGER INPUT socket. Quadrature FSK is achieved using both the TRIGGER INPUT and PULSE INPUT sockets. Also pulse modulation may be selected from a signal connected to the PULSE INPUT socket. These modulations may be used in the combinations shown in the table below. Additionally, an external signal applied to the EXT MOD INPUT socket can be combined with any selected modulation combination.

MODE

Set modulation mode

Data type : Character Program Data (valid combinations of AM, FM, PM, FSK2L, FSK4L or PULSE. See table below.)
 Allowed suffixes : None
 Default suffix : None

Examples: MODE AM,FM
 MODE FM,PULSE

VALID MODE COMBINATIONS TABLE

AM [,PULSE]
 FM [,PULSE]
 PM [,PULSE]
 AM,FM [,PULSE]
 AM,PM [,PULSE]
 FSK2L [,PULSE]
 FSK4L

Note...

Order is not important, for example AM,FM is equivalent to FM,AM. PULSE modulation can be used with any of the AM,FM,PM and FSK2L modes, but not with FSK4L.

FSK2L and FSK4L parameters are controlled using the FM commands. The frequency shifts produced by the applied data are as follows:

2FSK		4FSK		
TRIGGER	SHIFT	TRIGGER	PULSE	SHIFT
1	+D	1	0	+D
0	-D	1	1	+D/3
		0	1	-D/3
		0	0	-D

Where D is the set deviation value.

MODE?

Prepares message containing information on Modulation Mode in the following format:

:MODE <mode>

where: <mode> is character program data indicating the modulation mode settings

Example: :MODE AM,FM

Modulation control

These commands allow you to switch ALL modulation ON or OFF.

MOD	[not used alone]
:ON	Turn modulation globally ON
:OFF	Turn modulation globally OFF

Examples: MOD:ON
MOD:OFF

MOD? Prepares message containing information on Modulation Control in the following format:

:MOD:<status>

where: <status> is a program mnemonic indicating whether the Modulation is globally ON or OFF

Example: :MOD:ON

Frequency modulation (and FSK)

These commands enable you to select frequency modulation either as a single modulation or as the sum of two signals, to set the deviation rate, to switch the modulation on and off and to perform DC FM nulling. (For the latter, ensure that a ground reference is connected to the EXT MOD INPUT socket before you implement the command.) You can set the modulation oscillator frequency and select between sine, triangle and square waveforms. Also the phase difference of modulation oscillator channel 2 relative to channel 1 can be offset in degrees. Both deviation rate and modulation oscillator frequency can have their step sizes set and then be stepped up or down. And after having adjusted the deviation rate or the modulation oscillator frequency you can either return to the reference (rate or frequency) or make the current value the new reference.

FM or FM1 or FM2	Set FM Deviation (short form)
:DEVN	Set FM Deviation
:INC	Set FM step size
	Data type : Decimal Numeric Program Data
	Allowed suffices : Any one of: GHZ, MHZ, KHZ or HZ
	Default suffix : HZ
:<src>	Select modulation source where <src> is any one of: INT, EXTAC, EXTALC, or EXTDC
:ON	Turn FM ON (locally)
:OFF	Turn FM OFF (locally)
:UP	Go UP one step
:DN	Go DOWN one step
:RETN	Return to original setting
:XFER	Transfer current value to be the new setting
	Data type : None
	Allowed suffices : None
	Default suffix : None
	Examples: FM:DEVN 25KHZ;INT;ON FM1:DEVN 15KHZ;INC 1KHZ;EXTDC
:MODF	Set FM modulation oscillator frequency (short form)
:VALUE	Set FM modulation oscillator frequency
:INC	Set FM modulation oscillator frequency step size
	Data type : Decimal Numeric Program Data
	Allowed suffices : Any one of: GHZ, MHZ, KHZ or HZ
	Default suffix : HZ
:UP	Go UP one step
:DN	Go DOWN one step
:RETN	Return to original setting
:XFER	Transfer current value to be the new setting
:SIN	Select sinusoidal waveform
:TRI	Select triangle waveform
:SQR	Select square waveform
	Data type : None
	Allowed suffices : None
	Default suffix : None

:PHASE	Set phase offset of FM2 relative to FM1
Data type :	Decimal Numeric Program Data
Allowed suffices :	DEG
Default suffix :	DEG
Examples:	FM2:MODF:VALUE 1.5KHZ;SIN FM:MODF:PHASE 1.2DEG
DCFMNL	Perform DC FM null operation (only for EXTDC mode)
Data type :	None
Allowed suffices :	None
Default suffix :	None
Example:	DCFMNL
FM? or FM1? or FM2?	Prepares message containing information on FM setting in one of the following formats: :FM:DEVN <nr2>;<src>;<status>;INC <nr2> :FM1:DEVN <nr2>;<src>;<status>;INC <nr2> :FM2:DEVN <nr2>;<src>;<status>;INC <nr2> where: <src> is a program mnemonic representing the source of the modulation signal and <status> is a program mnemonic indicating whether the frequency modulation is locally ON or OFF
Example:	:FM1:DEVN 25000.0;INT;ON;INC 1000.0
FM:MODF? or FM1:MODF? or FM2:MODF?	Prepares message containing information on FM modulation oscillator setting in one of the following formats: :FM:MODF:VALUE <nr2>;<shape>;INC <nr2> :FM1:MODF:VALUE <nr2>;<shape>;INC <nr2> :FM2:MODF:VALUE <nr2>;<shape>;INC <nr2> where: <shape> is a program mnemonic representing the waveform shape
Example:	:FM1:MODF:VALUE 5750.00;SIN;INC 1000.00

Phase modulation

These commands enable you to select phase modulation either as a single modulation or as the sum of two signals, to set the deviation rate in radians, and to switch the modulation on and off. You can set the modulation oscillator frequency and select between sine, triangle and square waveforms. Also the phase difference of modulation oscillator channel 2 relative to channel 1 can be offset in degrees. Both deviation rate and modulation oscillator frequency can have their step sizes set and then be stepped up or down. And after having adjusted the deviation rate or the modulation oscillator frequency you can either return to the reference (rate or frequency) or make the current value the new reference.

PM or PM1 or PM2	Set Phase Modulation Deviation (short form)
:DEVN	Set Phase Modulation Deviation
:INC	Set Phase Modulation step size
	Data type : Decimal Numeric Program Data
	Allowed suffix : RAD
:<src>	Select modulation source where <src> is any one of: INT, EXTAC, EXTALC, or EXTDC
:ON	Turn PM ON (locally)
:OFF	Turn PM OFF (locally)
:UP	Go UP one step
:DN	Go DOWN one step
:RETN	Return to original setting
:XFER	Transfer current value to be the new setting
	Data type : None
	Allowed suffices : None
	Default suffix : None
	Examples: PM:DEVN 2.38RAD;INT;ON PM1:DEVN 1.5RAD;INC 0.1RAD;EXTAC
:MODF	Set PM modulation oscillator frequency (short form)
:VALUE	Set PM modulation oscillator frequency
:INC	Set PM modulation oscillator frequency step size
	Data type : Decimal Numeric Program Data
	Allowed suffices : Any one of: GHZ, MHZ, KHZ or HZ
	Default suffix : HZ
:UP	Go UP one step
:DN	Go DOWN one step
:RETN	Return to original setting
:XFER	Transfer current value to be the new setting
:SIN	Select sinusoidal waveform
:TRI	Select triangle waveform
:SQR	Select square waveform
	Data type : None
	Allowed suffices : None
	Default suffix : None
:PHASE	Set phase offset of PM2 relative to PM1
	Examples: PM1:MODF:VALUE 10.5KHZ;SQR PM2:MODF:PHASE 2.0DEG

PM? or PM1? or PM2?

Prepares message containing information on Phase Modulation setting in one of the following formats:

```
:PM:DEVN <nr2>;<src>;<status>;INC <nr2>
:PM1:DEVN <nr2>;<src>;<status>;INC <nr2>
:PM2:DEVN <nr2>;<src>;<status>;INC <nr2>
```

where <src> is a program mnemonic representing the source of the modulation signal and <status> is a program mnemonic indicating whether the phase modulation is locally ON or OFF

Example: :PM2:DEVN 2.30;INT;OFF;INC 0.05

PM:MODF? or PM1:MODF? or PM2:MODF?

Prepares message containing information on PM modulation oscillator setting in one of the following formats:

```
:PM:MODF:VALUE <nr2>;<shape>;INC <nr2>
:PM1:MODF:VALUE <nr2>;<shape>;INC <nr2>
:PM2:MODF:VALUE <nr2>;<shape>;INC <nr2>
```

where: <shape> is a program mnemonic representing the waveform shape.

Example: :PM2:MODF:VALUE 2500.00;TRI;INC 500.00

Amplitude modulation

These commands enable you to select amplitude modulation either as a single modulation or as the sum of two signals, to set the AM depth as a percentage, and to switch the modulation on and off. You can set the modulation oscillator frequency and select between sine, triangle and square waveforms. Also the phase difference of modulation oscillator channel 2 relative to channel 1 can be offset in degrees to a resolution of 0.1° . Both modulation depth and modulation oscillator frequency can have their step sizes set and then be stepped up or down. And after having adjusted the modulation depth or the modulation oscillator frequency you can either return to the reference (depth or frequency) or make the current value the new reference.

AM or AM1 or AM2	Set AM Depth (short form)
:DEPTH	Set AM Depth
:INC	Set AM step size
	Data type : Decimal Numeric Program Data
	Allowed suffices : PCT
	Default suffix : PCT
:<src>	Select modulation source where <src> is any one of: INT, EXTAC, EXTALC, or EXTDC
:ON	Turn AM ON (locally)
:OFF	Turn AM OFF (locally)
:UP	Go UP one step
:DN	Go DOWN one step
:RETN	Return to original setting
:XFER	Transfer current value to be the new setting
	Data type : None
	Allowed suffices : None
	Default suffix : None
	Examples: AM:DEPTH 30.5PCT;EXTAC;ON AM1:DEPTH 40PCT;INT;OFF
:MODF	Set AM modulation oscillator frequency (short form)
:VALUE	Set AM modulation oscillator frequency
:INC	Set AM modulation oscillator frequency step size
	Data type : Decimal Numeric Program Data
	Allowed suffices : Any one of: GHZ, MHZ, KHZ or HZ
	Default suffix : HZ
:UP	Go UP one step
:DN	Go DOWN one step
:RETN	Return to original setting
:XFER	Transfer current value to be the new setting
:SIN	Select sinusoidal waveform
:TRI	Select triangle waveform
:SQR	Select square waveform
	Data type : None
	Allowed suffices : None
	Default suffix : None
:PHASE	Set phase offset of AM2 relative to AM1
	Examples: AM2:MODF:VALUE 15.5KHZ;TRI;INC 500HZ AM:MODF:PHASE 5DEG

AM? or AM1? or AM2?

Prepares message containing information on Amplitude Modulation setting in one of the following formats:

```
:AM:DEPTH <nr2>;<src>;<status>;INC <nr2>  
:AM1:DEPTH <nr2>;<src>;<status>;INC <nr2>  
:AM2:DEPTH <nr2>;<src>;<status>;INC <nr2>
```

where <src> is a program mnemonic representing the source of the modulation signal and <status> is a program mnemonic indicating whether the amplitude modulation is locally ON or OFF

Example: :AM1:DEPTH 56.6;INT;ON;INC 5.0

AM:MODF? or AM1:MODF? or AM2:MODF?

Prepares message containing information on AM modulation oscillator setting in one of the following formats:

```
:AM:MODF:VALUE <nr2>;<shape>;INC <nr2>  
:AM1:MODF:VALUE <nr2>;<shape>;INC <nr2>  
:AM2:MODF:VALUE <nr2>;<shape>;INC <nr2>
```

where: <shape> is a program mnemonic representing the waveform shape

Example: :AM:MODF:VALUE 5000.00;TRI;INC 1000.00

Pulse modulation

You can use these commands to switch the pulse modulation on and off when it is part of the modulation mode. When ON is selected the carrier is modulated by the logic level applied to the PULSE INPUT socket.

Pulse ON Logic level between 3.5 and 5 V
Pulse OFF Logic level between 0 and 1.0 V

PULSE [not used alone]
:ON Turn Pulse modulation ON
:OFF Turn Pulse modulation OFF

Data type : None
Allowed suffices : None
Default suffix : None

Examples: PULSE : ON
 PULSE : OFF

PULSE? Prepares message containing information on Pulse Modulation setting in the following format:

:PULSE:<status>

where: <status> is a program mnemonic indicating whether the pulse modulation is ON or OFF

Examples: : PULSE : ON
 : PULSE : OFF

Memory stores

Carrier store

The non-volatile carrier frequency store has 100 locations numbered 0 to 99 for the storage of carrier frequency only. This store can be used to apply a set of test conditions to a range of frequencies. For example, if you wish to use the same modulation at a variety of frequencies you can use the carrier store to set the instrument to each of the frequencies in turn. When a carrier store is recalled it will only replace the current carrier frequency - all the other settings will remain unchanged.

Full store

The non-volatile full store has 100 locations numbered 100 to 199 for the storage of instrument settings. This store is used to store those parameters which currently affect the RF output; carrier frequency, RF level, modulations in use, on/off and source information and the two modulation oscillator frequencies in use.

A full store contains the following information:

- Carrier frequency setting
- Carrier frequency step size
- RF level setting
- RF level step size
- All modulation settings
- All modulation step sizes
- Modulation mode and status
- The active modulation frequencies
- The modulation frequency step size
- All sweep settings

RAM store

The volatile RAM store has 100 locations numbered from 200 to 299 for the full storage of instrument settings. The parameters stored are the same as those for the full store. However, the RAM store has no long term wear-out mechanism and is therefore recommended for use in ATE programs where all the settings to be used in a test sequence are initially declared and then recalled. This results in a reduction of the 488.2 message overhead.

Memory - store

STO	Store 0-299 (short form)
:MEM	Store 0-299
:CFRQ	Carrier Freq Store 0-99
:FULL	Full Store 100-199
:RAM	RAM Store 200-299
Data type :	Decimal Numeric Program Data
Allowed suffices :	None
Default suffix :	None
Examples:	STO:FULL 112 STO:CFRQ 83

Memory-recall

There are three types of recall: carrier, full and RAM. Both carrier and full stores are non-volatile. The contents of the RAM store are lost when the instrument is switched off.

Carrier recall

The non-volatile carrier frequency store has 100 locations numbered 0 to 99 for carrier frequency only. These can be recalled and used in conjunction with full recall to apply a set of test conditions to a range of frequencies.

Full recall

The non-volatile full store has 100 locations numbered 100 to 199 for the storage of instrument settings. These stores may be recalled and used to reset the instrument's parameters to those which affect the RF output: carrier frequency, RF level, modulations in use, on/off and source information and the two modulation oscillator frequencies in use.

RAM recall

The volatile RAM store has locations numbered 200 to 299 for the full storage of instrument settings. The parameters that are recalled are the same as those for full recall.

Recalling default settings

For a list of the default settings see Table 3-1.

Memory-recall

To recall the factory default settings, enter : MEM RCL 999 or use *RST.

RCL	Recall Store 0-299 (short form)
:MEM	Recall Store 0-299
:CFRQ	Recall Carrier Freq Store 0-99
:FULL	Recall Full Store 100-199
:RAM	Recall RAM Store 200-299
	Data type : Decimal Numeric Program Data
	Allowed suffices : None
	Default suffix : None
:UP	Step up through stores. Use this command for memory sequencing
:DN	Step down through stores. Use this command for memory sequencing
	Data type : None
	Allowed suffices : None
	Default suffix : None
	Examples: RCL:FULL 125 RCL:UP
RCL?	Prepares message containing information on last memory store that was recalled in the following format: :RCL:MEM <nr1>
	Examples: :RCL:MEM 126

Memory - erase

ERASE	[not used alone]
:CFRQ	Erase all Carrier Freq Stores (0-99)
:FULL	Erase all Full Stores (100-199)
:RAM	Erase all RAM Stores (200-299)
:ALL	Erase <u>all</u> Stores (0-299)
	Data type : None
	Allowed suffices : None
	Default suffix : None
	Examples: ERASE:FULL ERASE:ALL

Memory - sequencing

These commands enable you to step through the memory stores in a sequence. For triggering, refer to 'Memory-triggering' below.

MSEQ	[not used alone]
:MODE	Select sequencing mode of operation. When a sequence is selected, the user can step through the sequence using the RCL:UP and RCL:DN commands. The sequence modes are SEQ1 to SEQ9, and the sequencing can be disabled with the OFF parameter.
	Data type : Character Program Data
	Allowed suffices : None
	Default suffix : None
	Examples: MSEQ:MODE OFF MSEQ:MODE SEQ2
:SEQ1...:SEQ9	
:START	Set the memory store for the start of the sequencing loop
:STOP	Set the memory store for the end of the sequencing loop
	Data type : Decimal Numeric Program Data
	Allowed suffices : None
	Default suffix : None
	Example: MSEQ:SEQ2:START 50;STOP 70
MSEQ?	Prepares message containing information on the current memory sequencing mode in the following format: :MSEQ:MODE <mode> where: <mseq> is character program data indicating the sequence mode selection
	Examples: :MSEQ:MODE SEQ4 :MSEQ:MODE OFF
MSEQ:SEQ1? MSEQ:SEQ9?	Prepares message containing information on the start and stop settings of the given memory sequence in the following format: :MSEQ:SEQn:START <nr1>;STOP <nr1> where <i>n</i> is between 1 and 9 inclusive
	Example: :MSEQ:SEQ4:START 120;STOP 155

Memory - triggering

For external triggering methods, refer to 'Trigger source' at the end of this section.

MTRIG

:ON Enables memory recall triggering to be activated by *TRG command or by external triggering

:OFF Disable memory recall triggering

Data type : None

Allowed suffices : None

Default suffix : None

Examples: MTRIG:ON
MTRIG:OFF

MTRIG?

Prepares message containing information on memory triggering state in the following format:

:MTRIG:<status>

where: <status> is a program mnemonic indicating whether the memory recall triggering is enabled (:ON) or disabled (:OFF)

Example: :MTRIG:ON

Memory - protection

These commands enable you to either write protect a block of stores (or a single store) to prevent accidental overwriting or to unprotect it. For a single store set both start and stop numbers the same. Note that any protection applied to RAM will be lost once the instrument has been switched off.

MPROT

[not used alone]

:START Set the start of the memory block which is to be protected/unprotected

:STOP Set the end of the memory block which is to be protected/unprotected

Data type : Decimal Numeric Program Data

Allowed suffices : None

Default suffix : None

:ON Set memory protection ON for the selected memory block

:OFF Set memory protection OFF (i.e. unprotected) for the selected memory block

Data type : None

Allowed suffices : None

Default suffix : None

Examples: MPROT:START 100;STOP 150
MPROT:ON

Sweep operation

These commands allow you to configure the instrument as a swept carrier signal generator where you define the start and stop frequencies, the step size and time per step. (Note that these commands also appear under 'Carrier frequency'.) To make these commands operational they must first be enabled by the CFRQ:MODE SWEPT command. For triggering methods, refer to 'Trigger source' at the end of this section.

SWEEP	[not used alone]
:CFRQ	Optional command (may be omitted)
:START	Set Start Frequency
:STOP	Set Stop Frequency
:INC	Set Carrier Frequency sweep step size
	Data type : Decimal Numeric Program Data
	Allowed suffices : Any one of: GHZ, MHZ, KHZ or HZ
	Default suffix : HZ
:LOGINC	PCT
:TIME	Select time per sweep step
	Data type : Decimal Numeric Program Data
	Allowed suffices : MS, S
	Default suffix : MS
	Example: SWEEP:CFRQ:START 100KHZ;STOP 500KHZ;INC 100HZ;TIME 60MS
SWEEP:CFRQ?	Prepares message containing information on Carrier Frequency Sweep settings in the following format: :SWEEP:CFRQ:START <nr2>;STOP <nr2>;INC;LOGINC<nr2>;TIME <nr2>
	Example: :SWEEP:CFRQ:START 1230000.0;STOP 1330000.0;INC 100.0;LOGINC 50.00;TIME 20.0

Sweep mode

To make these commands operational they must first be enabled by the CFRQ:MODE SWEPT command. These commands enable you to select the sweep mode between single shot and continuous sweep and between linear and logarithmic sweep. You can also select the triggering mode from the following:

OFF Disable the trigger.

START The first trigger input causes the carrier sweep to commence sweeping. Any other trigger inputs whilst sweeping are ignored. Only at the end of each sweep is the trigger latch reset ready for the next input.

STARTSTOP The first trigger input starts the carrier sweep and the following trigger input pauses it, so that the user can investigate a particular point of interest. The next trigger input continues the sweep from where it was paused. At the start of each sweep the trigger latch is reset ready for the next input.

STEP Each trigger input steps the sweep on by one frequency step. The trigger latch is reset after each step ready for the next step.

SWEEP [not used alone]

:MODE Select Mode of operation for Sweep generator (single or continuous)

Data type : Character Program Data (either SNGL or CONT)

Allowed suffices : None

Default suffix : None

Example: SWEEP:MODE SNGL

:TYPE Select type of sweep (linear or logarithmic)

Data type : Character Program Data (LIN or LOG)

Allowed suffices : None

Default suffix : None

Example: SWEEP:TYPE LOG

:TRIG

Data type : Character Program Data (any one of OFF, START, STARTSTOP, STEP)

Allowed suffices : None

Default suffix : None

Example: SWEEP:TRIG STARTSTOP

SWEEP? Prepares message containing information on Sweep Mode type and trigger in the following format:

:SWEEP:MODE <mode>;TYPE<type>;TRIG<trig>

where: <mode> is character program data indicating the sweep mode selected, <type> is character program data indicating type selected, and <trig> is character program data indicating the trigger type selected

Example: :SWEEP:MODE CONT;TYPE LOG;TRIG STEP

Sweep control

To make these commands operational they must first be enabled by the CFRQ:MODE SWEPT command. These commands enable you to start the sweep in the selected increments from the chosen reference frequency, pause the sweep, step the sweep up or down from the paused position, and continue the sweep. At any time when the sweep is stopped you can either return to the reference frequency or transfer the current frequency as the new reference frequency.

SWEEP	[not used alone]
:GO	Commence Sweep
:HALT	Pause Sweep
:CONT	Continue Sweep
:RESET	Reset sweep to Start Value
:RETN	Return to original setting
:XFER	Transfer current value as the new setting
:UP	Go UP one sweep step while paused
:DN	Go DOWN one sweep step while paused

Data type : None
Allowed suffices : None
Default suffix : None

Examples: SWEEP:GO
SWEEP:RESET

Trigger source

These commands enable you to disable the trigger, select the trigger source from one of the eight VXI backplane triggers or to select an external trigger. For external triggering, connect a TTL trigger signal to the TRIGGER INPUT connector. Ensure however, that this socket is not disabled for your application by a higher priority mode having been selected. The order of priority is as follows:

FSK logic input
Memory sequencing
Sweep trigger

All three modes of operation may be enabled at the same time, but only one mode will be active, the one with the highest priority. Therefore ensure that, for example, FSK and memory sequencing are not enabled when selecting sweep triggering otherwise the triggering will have no effect. Trigger source selection is as follows:

TRIGGER

:SOURCE Select trigger source.

Data type : Character Program Data (HOLD, IMMEDIATE, TTLTRG0, TTLTRG1, TTLTRG2, TTLTRG3, TTLTRG4, TTLTRG5, TTLTRG6, TTLTRG7, BUS, EXTERNAL). HOLD means no trigger.

Allowed suffices : None

Default suffix : None

Example: TRIGGER:SOURCE EXTERNAL

TRIGGER:SOURCE?

Prepares message containing information on Trigger Source setting in the following format:

:TRIGGER:SOURCE <source>

where <source> is character program data defining the trigger source.

Examples: :TRIGGER:SOURCE EXTERNAL
:TRIGGER:SOURCE TTLTRG3

Sources

BUS: The trigger is generated over the GPIB or VXI interface. The group execute trigger (GET) provides the trigger over IEEE 488.1

HOLD: Selecting this means the event detection is disabled.

IMMEDIATE: No waiting for an event to occur.

TTLTRG 0-7: The VXI backplane TTLTRG triggers provide the source.

EXTERNAL: An external trigger is provided via the TRIGGER INPUT socket.

Miscellaneous commands

Attenuator hold

The ATTEN:LOCK command allows you to reduce the RF level by at least another 10 dB without the step attenuator operating.

ATTEN	[not used alone]
:LOCK	Lock the Attenuators
:UNLOCK	Unlock the Attenuators

Data type : None
 Allowed suffices : None
 Default suffix : None

Example: ATTEN:LOCK

ATTEN? Prepares message containing information on whether the Attenuators are locked or unlocked in the following format:

:ATTEN:<status>

where <status> is a program mnemonic indicating whether the attenuators are locked or unlocked.

Example: :ATTEN:LOCK

Table 3-2 below applies to software versions 1.03 onwards. Maximum level with attenuator lock on will reduce if AM or pulse modulation is applied. Any user programmed limits for RF level or offsets will also affect the attenuator lock ranges.

Table 3-2 Attenuator lock ranges

RF level setting (dBm)		Atten. lock (min. dBm)	Atten. lock (max. dBm)
from	to		
+26.0	+18.0	+7	+25
+17.9	+7.1	-4	+24
+7.0	+7.0	-4	+13
+6.9	-4.0	-15	+13
-4.1	-15.0	-26	+2
-15.1	-26.0	-37	-9
-26.1	-37.0	-48	-20
-37.1	-48.0	-59	-31
-48.1	-59.0	-70	-42
-59.1	-70.0	-81	-53
-70.1	-81.0	-82	-54
-81.1	-92.0	-103	-75
-92.1	-103.0	-114	-86
-103.1	-114.0	-125	-97
-114.1	-125.0	-136	-108
-125.1	-136.0	-137	-119
-136.1	-137.0	-137	-130

Power-up options

These commands allow you to select between powering up with the factory settings (given in Table 3-1) or with the settings of your choice stored in one of the full memory locations (range 100 to 199) or carrier frequency memory locations (range 0 to 99).

POWUP	[not used alone]
:MODE	Select the power up mode. The instrument can power up in either the factory preset mode or from a selected memory
	Data type : Character program data (FACTORY or MEMORY)
	Allowed suffices : None
	Default suffix : None
:MEM	Set the memory location for a memory power up
	Data type : Decimal Numeric Program Data
	Allowed suffices : None
	Default suffix : None
	Example: POWUP:MODE MEMORY POWUP:MEM 172
POWUP?	Prepares message containing information on the instrument power up selection in the following format:
	Example: :POWUP:MODE MEMORY;MEM 135

Reverse power protection

Accidental application of power to the RF OUTPUT socket trips the reverse power protection circuit. The following commands enable you to detect when the protection circuit has been tripped, reset the protection (after you have removed the source from the socket), and find out how many times the circuit has tripped.

RPP	Reset reverse power protection trip (short form)
:RESET	Reset RPP trip
	Data type : None
	Allowed suffices : None
	Default suffix : None
	Example: RPP:RESET
RPP:TRIPPED?	Prepares message containing information on whether the RPP circuit is currently tripped in the following format: <nr1> (0 = not tripped, 1 = tripped)
	Example: 1
RPP:COUNT?	Prepares message containing information on the number of times the RPP circuit has tripped in the following format: <nr1>
	Example: 3

Operating hours

These commands enable you to find out either the total operating hours or the elapsed operating hours since the last reset, as well as to reset the elapsed time to zero.

ELAPSED	Reset elapsed operating hours to zero
:RESET	
	Data type : None
	Allowed suffices : None
	Default suffix : None
	Example: ELAPSED:RESET
ELAPSED?	Prepares message containing information on elapsed operating hours since last reset in the following format: <nr2>
	Example: 454 . 50
OPER?	Prepares message containing information on total operating hours in the following format: <nr2>
	Example: 1453 . 00

Frequency standard selection

These commands enable you to select a 10 MHz output to provide a standard for use with associated equipment, as well as enabling you to select a standard (either external or internal) for use by the instrument. When an external standard is selected, the internal TCXO is locked to the external standard using a phase locked loop. In this case, you can select between *direct* and *indirect*. When *direct* is selected the internal standard for the RF tray is provided directly from the external standard. When *indirect* is selected this standard is provided from the TCXO locked to the external standard. You should select *direct* if your provided standard is better than that fitted in the instrument.

FSTD Select internal or external frequency standard

Data type : Character program data (any one of INT, EXT10DIR, EXT1IND, EXT10IND or INT10OUT)

Allowed suffices : None

Default suffix : None

Examples: FSTD INT
FSTD EXT10IND

FSTD? Prepares message containing information on frequency standard selection in the format:

:FSTD <char>

Example: :FSTD EXT10IND

Reading error messages

This command enables the error messages to be read off the error queue in the order that they occurred. Error messages are explained and listed at the end of this chapter.

ERROR? Prepares message relating to the next error in the error queue in the following format:

<nr1>, <string>

Where <string> is a descriptive error message. The numeric value returned is either that of the next error number or 0 if the queue is empty or 399 if the queue is full

Example: 100, "Carrier Limit"

Status byte

The Status Byte provides information about events and conditions within the instrument. It may be read by a conventional Serial Poll or its value obtained as a response to the *STB? query. Bits 0 to 5 and bit 7 are each single bit Summary Messages which may be of two types (or not used at all).

- (i) Queue Status - a '1' indicates that an associated Queue is non-empty and has data available to be read.
- (ii) Status Register Summary - reports the occurrence of an enabled event monitored by a Status Register Structure.

The Service Request Enable Register determines which of the bits can generate an SRQ. This register may be set by *SRE or read by *SRE?. If the bitwise -AND of the Status Byte and the Enable Register is non-zero the Flag Master Summary Status (<mss>) is True. Bit 6 of the Status Byte value read by *STB? holds <mss>. However bit 6 of the Status Byte when Serial Polled is the Request For Service bit used to determine which device on the Bus has asserted SRQ, and is cleared by a Serial Poll.

The IEEE 488.2 Standard defines bit 4 as Message Available (<mav>), the Queue Summary for the Output Buffer, indicating whether any part of a Response Messages is available to be read. Bit 5 is the Event Summary Bit (<esb>), the Summary Message from the Standard Event Status Register.

With this instrument, bit 7 is a Queue Summary for the Error Queue. Bits 1, 2, and 3 are Status summaries for the Instrument Status, Coupling Status and Hardware Status Registers. Bit 0 is unused.

Status data structure - register model

Below is a generalised model of the Register Set which funnels the monitored data into a single summary bit to set the appropriate bit in the Status Byte.

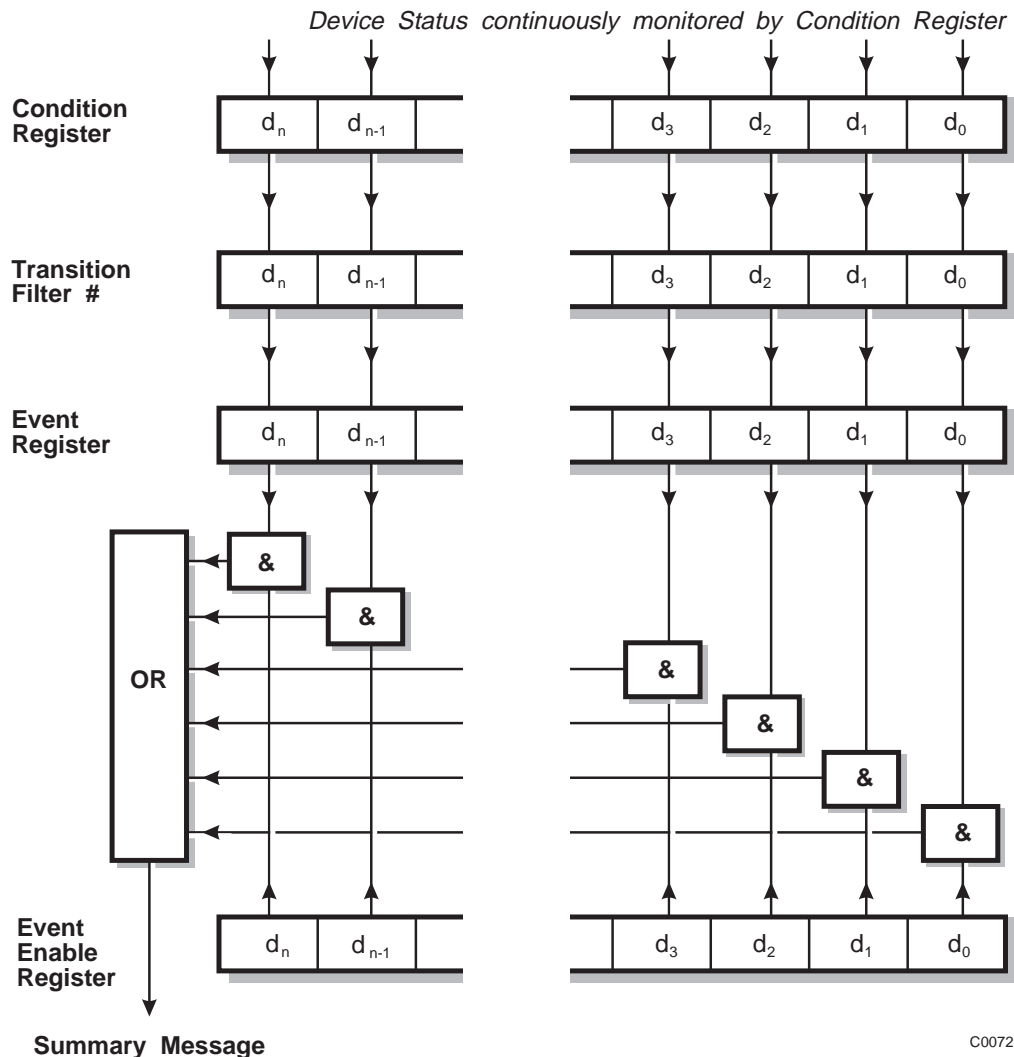

PROGRAMMING

Note

The Device Status is continuously monitored by the Condition Register. If a Query to read a Condition Register is provided, the Response represents the Status of the instrument at the moment the Response is generated. A Condition Register cannot be written to.

The Transition Filter determines which transition of the Condition Register data bits will set the corresponding bit in the Event Register. Either positive-going, negative-going or both transitions can set bits in an Event Register. But with this instrument the Transition Filters are pre-set as either Positive or Negative, as described in the following pages.

The bits in an Event Register are "latched". Once set they remain set, regardless of subsequent changes in the associated condition bit until the Event Register is cleared by being read or by the *CLS common command. Once cleared, an Event Register bit will only be set again if the appropriate change in the Condition bit occurs.

The Event Enable Register may be both written to and read from. It is bitwise AND-ed with the Event Register and if the result is non-zero the Summary Message is true, otherwise the Summary Message is false. Enable Registers are not affected by *CLS but are however clear at power-on.

Standard event registers

This register is defined by IEEE 488.2 and each bit has the meaning shown below:-

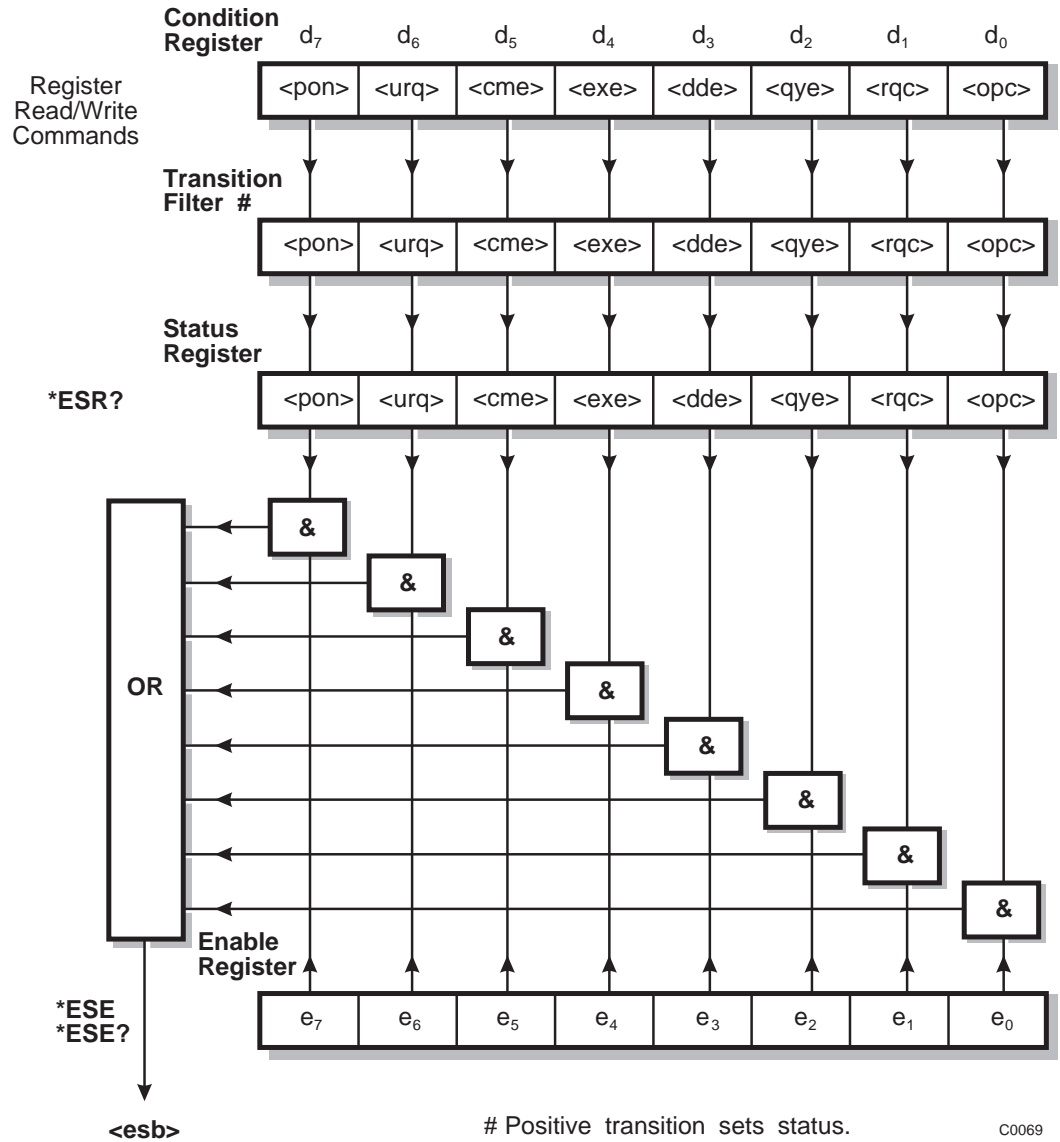

- <pon> power on
- <urq> user request - not implemented in this product
- <cme> command error
- <exe> execution error
- <dde> device dependent error
- <qye> query error
- <rqc> request control - not implemented in this product
- <opc> operation complete - set in response to the *OPC command for synchronisation.

- <esb> standard event register summary bit

Hardware event registers

This is a device dependent register and the bits have meanings as shown in the list at the bottom of the page.

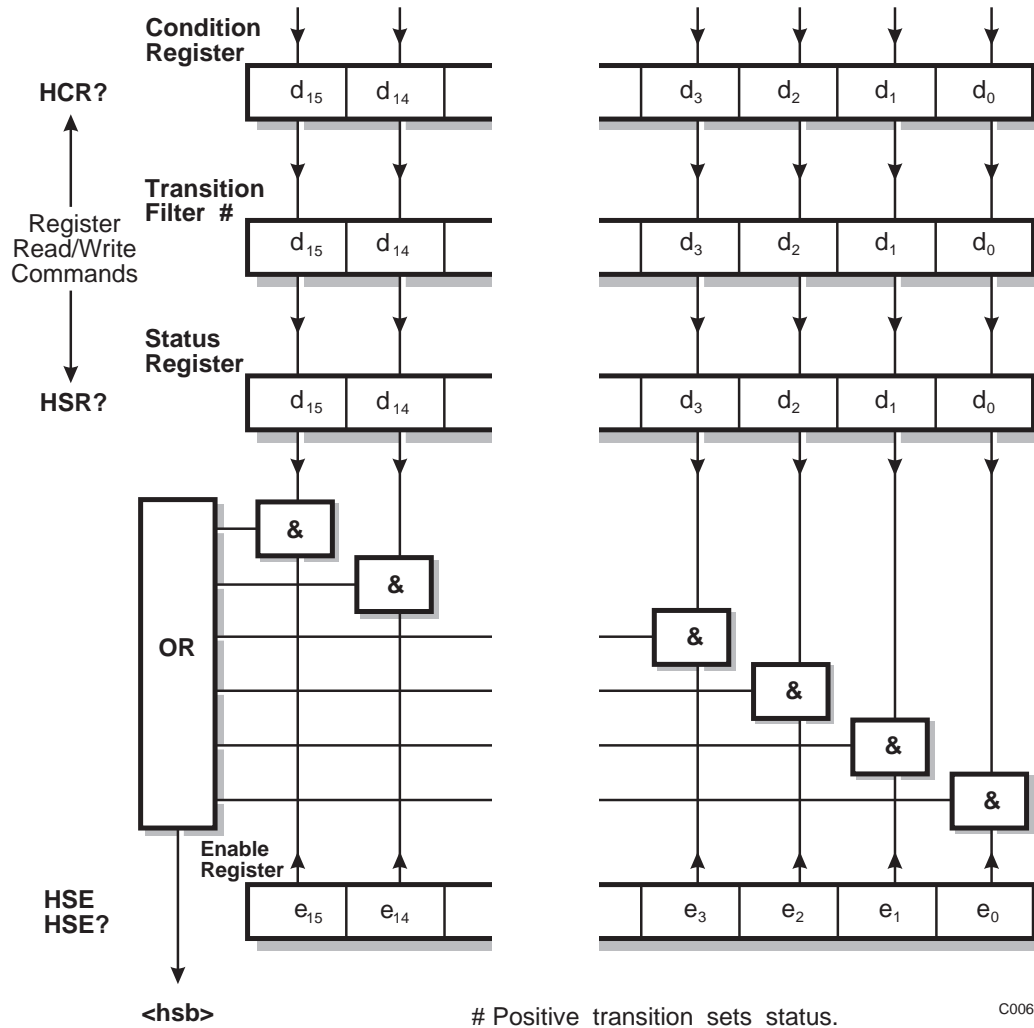

PROGRAMMING

- | | | | |
|----------------|--------------------------------------|-----------------|-----------------------------|
| d ₀ | reverse power protection tripped | d ₈ | filter unlevelled |
| d ₁ | fractional-n loop low | d ₉ | output unlevelled |
| d ₂ | fractional-n loop high | d ₁₀ | high power amplifier failed |
| d ₃ | external standard missing | d ₁₁ | ALC too high |
| d ₄ | external standard frequency too low | d ₁₂ | ALC too low |
| d ₅ | external standard frequency too high | d ₁₃ | DSP not responding |
| d ₆ | VCXO loop low | d ₁₄ | not used |
| d ₇ | VCXO loop high | d ₁₅ | not used |

<hsb> hardware event register summary bit

Coupling event registers

This is a device dependent register and the bits have meanings as shown in the list at the bottom of the page.

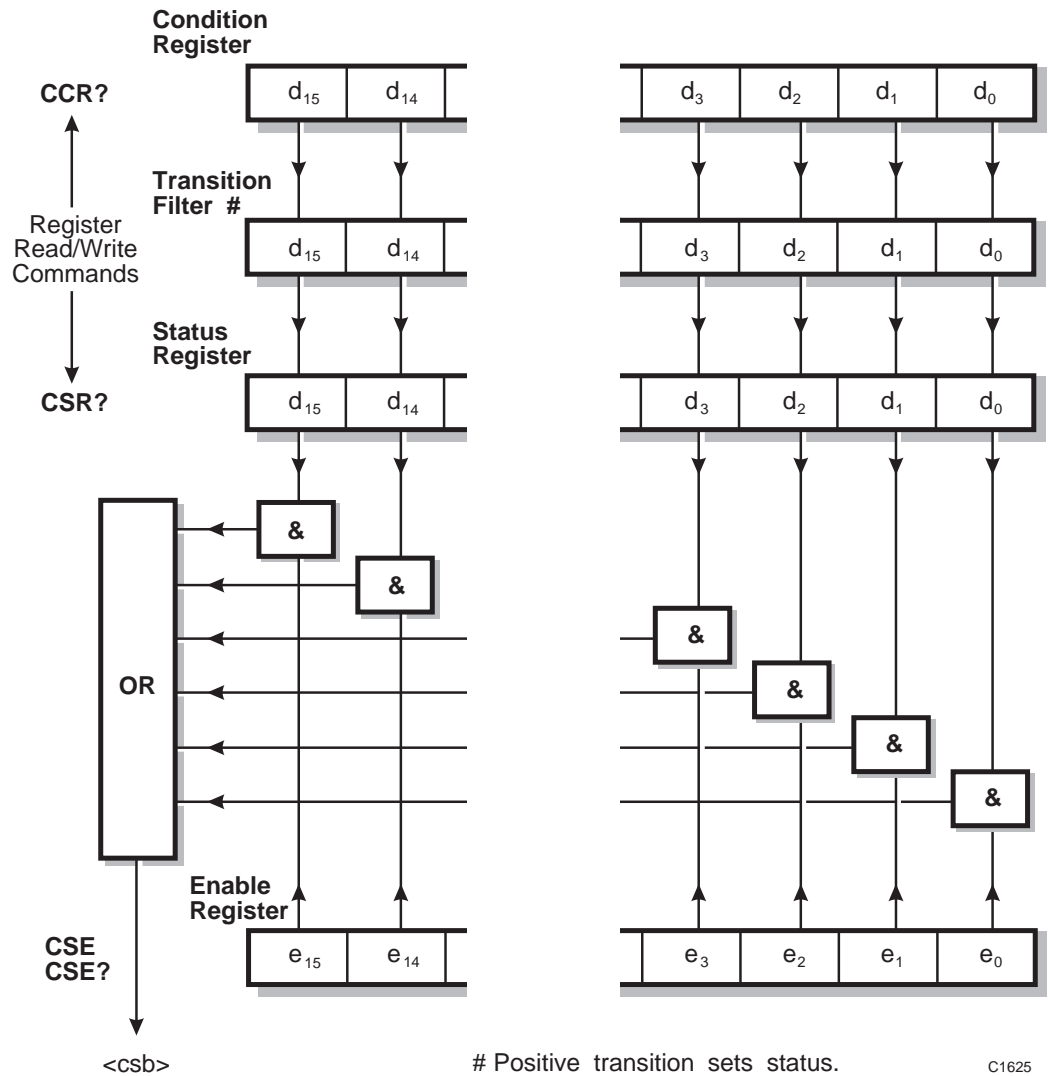

- d_0 RF level restricted by requested AM depth
- d_1 not used
- d_2 not used
- d_3 AM2 depth restricted by requested AM1 depth
- d_4 FM2 deviation restricted by requested FM1 deviation
- d_5 Φ M2 deviation restricted by requested Φ M1 deviation
- d_6 not used
- $d_7 - d_{15}$ not used
- <csb> coupling event register summary bit

Instrument event registers

This is a device dependent register and the bits have meanings as shown in the list at the bottom of the page.

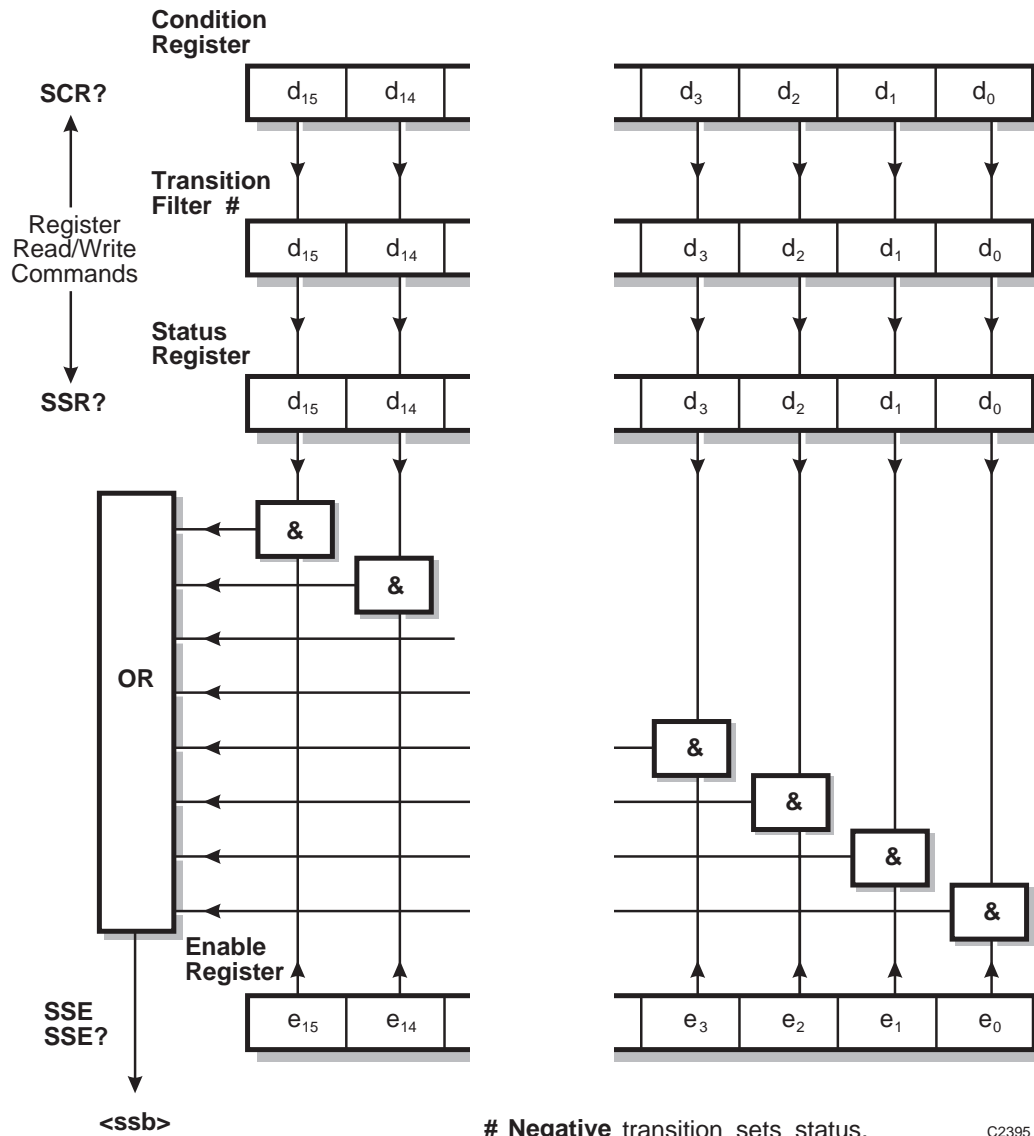

PROGRAMMING

Negative transition sets status.

C2395

	<u>Condition (SCR?)</u>	<u>Event Status (SSR?)</u>
d ₀	sweep in progress	end of sweep
d ₁	not used	not used
d ₂	selfcal in progress	selfcal completed
d ₃	DC FM null in progress	DC FM null completed
d ₄ - d ₁₅	not used	not used
<ssb>	instrument event register summary bit	

Queue flag details

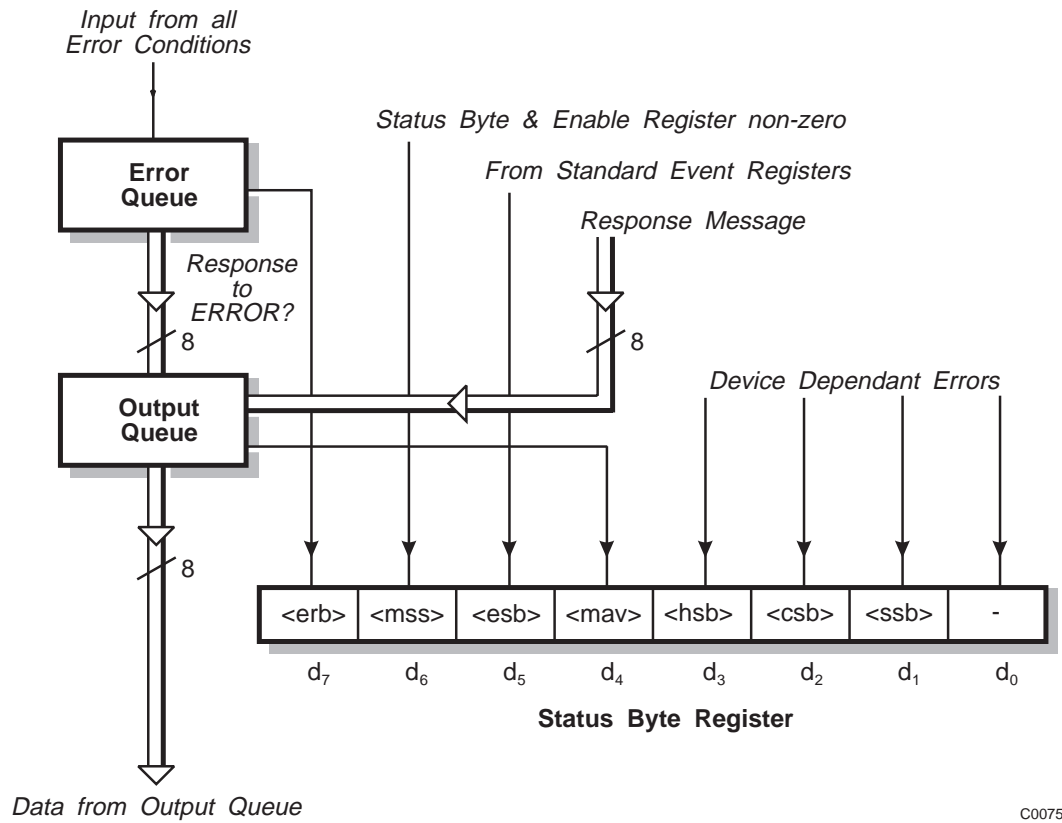

C0075

The <mav> status bit is set when one or more bytes are available to be read from the Output Queue. The <erb> status bit is set when one or more errors are present in the Error Queue. The ERROR? query will place a nr1 and string response message in the Output Queue representing the error at the head of the queue. If the queue is empty this message will be 0, "No error".

Status byte when read by *STB?

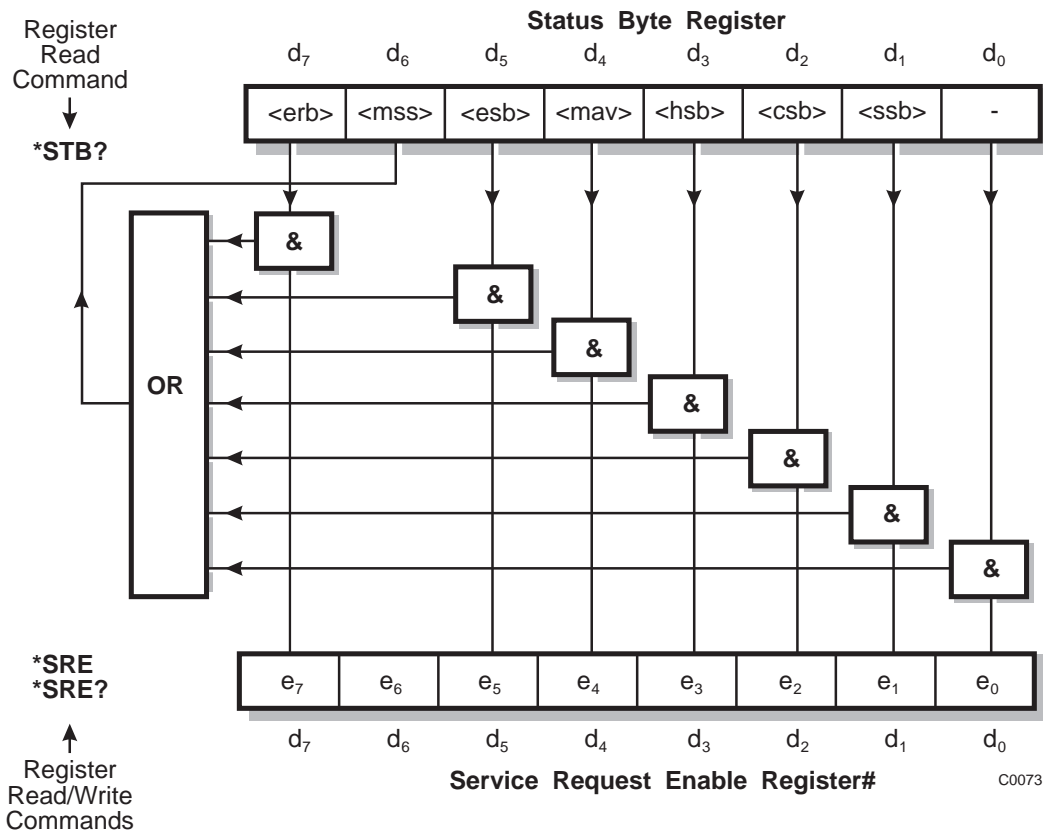

PROGRAMMING

Bit 6 in this register ignores data sent by *SRE and always returns 0 in response to *SRE?

<rqs>, <esb> and <mav> are defined in IEEE 488.2

- <erb> is a device defined queue summary bit indicating that the error queue is non-empty.
- <mss> is true when (Status Byte) AND (Enable register) > 0.
- <esb> is the standard event register summary bit.
- <mav> is 'message available' indicating that the output queue is non-empty.
- <hsb> is 'hardware status' summary bit
- <csb> is 'coupling status' summary bit
- <ssb> is 'instrument status' summary bit

Note

The Status Byte Register is Not cleared by the *STB? query.

Status byte when read by serial poll

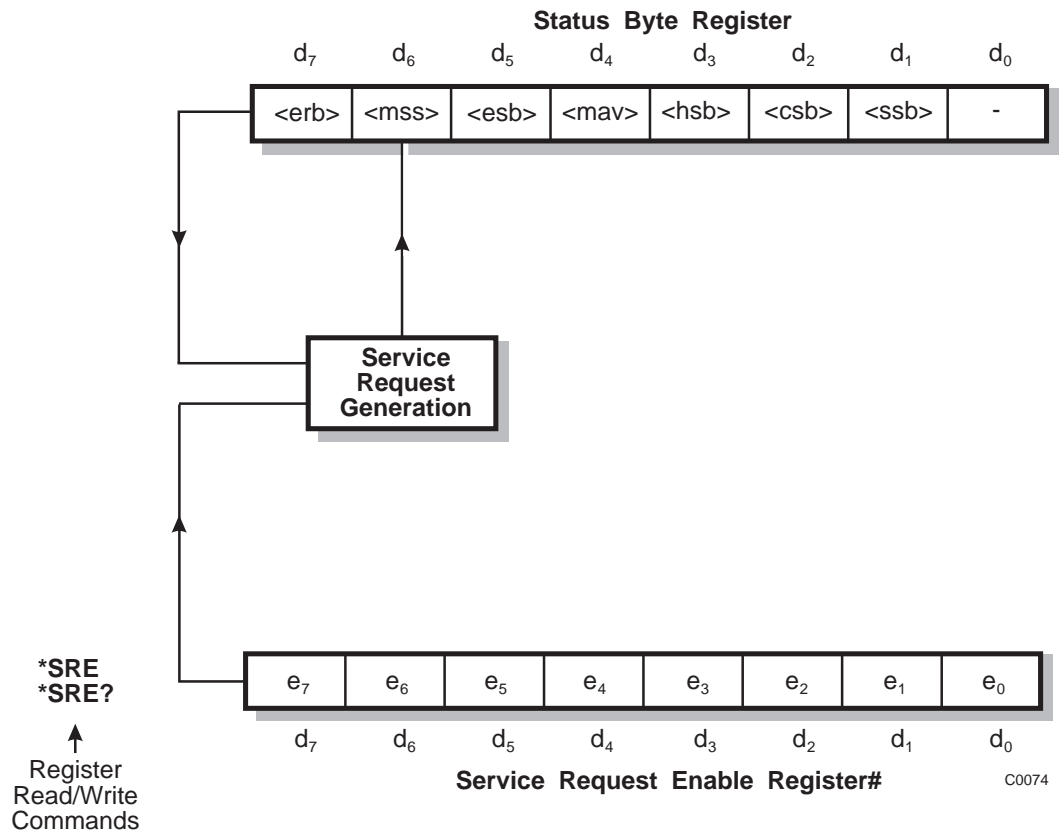

Bit 6 in this register ignores data sent by *SRE and always returns 0 in response to *SRE?

$\langle \text{erb} \rangle$ is a device defined queue summary bit indicating that the error queue is non-empty.

$\langle \text{rqs} \rangle$ is set by a request for service and is cleared by the poll.

$\langle \text{esb} \rangle$ is the standard event register summary bit.

$\langle \text{mav} \rangle$ is 'message available' indicating that the output queue is non-empty.

$\langle \text{hsb} \rangle$ is 'hardware status' summary bit

$\langle \text{csb} \rangle$ is 'coupling status' summary bit

$\langle \text{ssb} \rangle$ is 'instrument status' summary bit

$\langle \text{rqs} \rangle$, $\langle \text{esb} \rangle$ and $\langle \text{mav} \rangle$ are defined in IEEE 488.2

$\langle \text{rqs} \rangle$ (request for service) will produce an SRQ at the controller. It is set by a change to either the Status Byte or the Service Enable Register that results in a New Reason for Service. It is cleared when $\langle \text{mss} \rangle$ goes FALSE (i.e. no reason for service) or by Serial Poll.

Summary of status reporting commands and queries

*CLS	Clears Status Registers and the Error Queue
*ESE<nrf>	Writes to Standard Event Enable Register
*ESE?	Reads from Standard Event Enable Register
*ESR?	Reads from Standard Event Status Register
*SRE<nrf>	Writes to Service Request Enable Register
*SRE?	Reads from Service Request Enable Register
*STB?	Reads from Status Byte Register
CCR?	Reads from Coupling Condition Register
CSE<nrf>	Writes to Coupling Status Enable Register
CSE?	Reads from Coupling Status Enable Register
CSR?	Reads from Coupling Status Register
HCR?	Reads from Hardware Condition Register
HSE<nrf>	Writes to Hardware Status Enable Register
HSE?	Reads from Hardware Status Enable Register
HSR?	Reads from Hardware Status Register
SCR?	Reads from Instrument Condition Register
SSE<nrf>	Writes to Instrument State Enable Register
SSE?	Reads from Instrument State Enable Register
SSR?	Reads from Instrument State Status Register
<nrf>	Decimal Numeric Program Data

All of the above queries respond with a nr1 numeric format.

Error messages

Error handling

Error messages are divided into four groups:

- (1) Background errors - represent a condition of the instrument.
- (2) Foreground errors - generally caused by the user.
- (3) IEEE488.2 errors - generated by incorrect programming.
- (4) Fatal errors - caused by failure associated with the main RAM or the PROM.

The instrument software detects error conditions as they occur. This information can be obtained by periodic checking of the error queue or the status byte, or by setting up the interface to produce interrupts when errors occur.

Background errors:

These are generated due to an incorrect operating condition within the instrument. These errors are generated automatically to warn the operator. For example if the reverse power protection circuit should trip error *500: (RPP tripped)* will be placed in the error queue. Background errors are listed in Table 3-3.

Foreground errors:

These are typically generated when an entered parameter value is outside the valid range or for some other invalid operation. For example trying to set the carrier frequency above or below the specified range will put the error *100: (Carrier limit)* into the error queue. Foreground errors are listed in Table 3-4.

Error queue

When an error occurs the error number is put into the error queue. The error at the head of the queue is only cleared by the `ERROR?` query, which returns that error, or by the `*CLS` command which clears the whole error queue. IEEE 488.2 errors are listed in Table 3-5.

The queue holds a maximum of 64 error message error numbers. If an error occurs while the queue is full the last error number is replaced with 399 to indicate that the queue is full. The `ERROR?` query returns a value of 399 for queue full and 0 for queue empty.

When an error number is written into the queue, a bit (`<erb>`) in the status byte register is set, and an appropriate bit in the standard event register is also set (one of `<cme>`, `<exe>`, `<dde>` or `<qye>`). These errors will also generate a VXI controller interrupt for the event 'Request True' if the appropriate interface settings have been set up. Many background errors are also reported in the Hardware and Coupling Status Registers.

Table 3-3 Background errors (500 - 599) in priority order

-	-	-	591	ftl	Main PROM faulty
590	ftl	Main RAM faulty	-	-	-
-	-	-	-	-	-
-	-	-	-	-	-
-	-	-	-	-	-
500	dde	RPP tripped	501	dde	Fractional-N loop low
502	dde	Fractional-N loop high	503	dde	Ext standard missing
504	dde	External std frequency low	505	dde	External std frequency high
506	dde	VCXO loop low	507	dde	VCXO loop high
508	dde	Amplitude modulator unlevelled	509	dde	Output unlevelled
510	dde	High power amplifier failed	511	dde	ALC too high
512	dde	ALC too low	513	dde	DSP not responding
-	-	-	-	-	-
-	-	-	-	-	-
-	-	-	549	exe	RF level uncalibrated
550	exe	RF level limited by AM	551	exe	AM2 limited by AM1
552	exe	FM2 limited by FM1	553	exe	ΦM2 limited by ΦM1

PROGRAMMING

Table 3-4 Foreground errors (0 - 399)

0	dde	No error	1	dde	EEPROM checksum
2	dde	Pad cal checksum	3	dde	RF cal checksum
4	dde	Freq std checksum	5	dde	Synthesizer cal checksum
6	dde	Mod ref checksum	7	dde	Mod offset checksum
8	dde	Mod amp checksum	9	dde	ALC cal checksum
10	dde	FM cal factor checksum	11	dde	FM tracking checksum
12	dde	Φ M cal factor checksum	13	dde	System cal checksum
14	dde	AM cal checksum	15	dde	Store checksum
16	dde	Image checksum	-	-	-
20	dde	Frac-N out of lock at <freq>	21	dde	VCO cal fail at <freq>
22	dde	VTF tune cal fail at <freq>	23	dde	FM tracking cal fail at <freq>
-	-	-	51	dde	*Keyboard buffer overflow
52	dde	*Display buffer overflow	53	dde	*Display missing
-	-	-	-	-	-
100	exe	Carrier limit	101	exe	Carrier step limit
102	exe	RF level limit	103	exe	RF level step limit
104	exe	Invalid modulation mode	105	exe	AM limit
106	exe	AM2 limit	107	exe	AM step limit
108	exe	AM2 step limit	109	exe	FM limit
110	exe	FM2 limit	111	exe	FM step limit
112	exe	FM2 step limit	113	exe	Φ M limit
114	exe	Φ M2 limit	115	exe	Φ M step limit
116	exe	Φ M2 step limit	117	exe	Memory limit
118	exe	AM mod freq limit	119	exe	AM mod step limit
120	exe	AM2 mod freq limit	121	exe	AM2 mod step limit
122	exe	FM mod freq limit	123	exe	FM mod step limit
124	exe	FM2 mod freq limit	125	exe	FM2 mod step limit
126	exe	Φ M mod freq limit	127	exe	Φ M mod step limit
128	exe	Φ M2 mod freq limit	129	exe	Φ M2 mod step limit
130	exe	Return/Transfer not allowed	131	exe	*Util limit
132	exe	Start freq limit	133	exe	Stop freq limit
134	exe	Sweep time limit	135	exe	Sweep mode disabled
136	exe	Carrier phase limit	137	exe	AM phase limit
138	exe	FM phase limit	139	exe	Φ M phase limit
140	exe	Memory store limit	141	exe	Memory recall limit
142	exe	*Display blanking limit	143	exe	*GPIB address limit
144	exe	Latch address limit	145	exe	Latch data limit
146	exe	Freq std carrier limit	147	exe	Freq std course adj limit
148	exe	Freq std fine adj limit	149	exe	Mod ref adj limit
170	exe	*Util not available	171	exe	Entry outside limits
172	exe	Data out of range	173	exe	Units not valid
174	exe	Unlev fact limited by FM fact	175	exe	*Invalid baud rate
176	exe	*Data overrun	177	exe	*Data parity
178	exe	*Data framing	179	exe	*Break in data
180	exe	*Transmit buffer full	181	exe	*Receiver not enabled
182	exe	*Protected utility - Level 1	183	exe	*Protected utility - Level 2
184	-	-	185	exe	This store is Read Only
186	-	-	187	-	-
188	exe	Pulse unavailable in 4FSK mode	189	exe	Pulse has been disabled
190	exe	No attenuator fitted	191	exe	No high power amp fitted
192	-	-	193	exe	Ext DCFM mod mode required
398	-	-	399	exe	Error queue full

* These errors are not used in this instrument

Table 3-5 IEEE 488.2 errors (400 - 499)

400	cme	Syntax error	401	cme	Unrecognised mnemonic
402	cme	Numeric syntax	403	cme	Data expected
404	cme	Illegal data	405	cme	Too much data
406	cme	Incorrect data type	407	cme	Unrecognised character data
408	cme	Character data not unique	409	cme	Block definition
410	cme	Block size	411	cme	Missing quote
412	cme	Terminator expected	413	cme	Invalid unit
414	cme	Unit not expected	415	cme	No header match found
416	cme	Header not unique	417	cme	Illegal star command
418	cme	Sub-command not allowed	419	cme	Action not allowed with header
420	cme	Query not allowed with header	421	cme	Parser decode
-	-	-	-	-	-
-	-	-	-	-	-
-	-	-	-	-	-
-	-	-	-	-	-
450	qye	Query INTERRUPTED	451	qye	Query UNTERMINATED
452	qye	Query DEADLOCK	453	qye	Query lost after arbitrary char
-	-	-	-	-	-
-	-	-	-	-	-
-	-	-	-	-	-

PROGRAMMING

Chapter 4

TECHNICAL DESCRIPTION

Introduction

The 3271 VXI Signal Generator is a VXI module which covers a wide range of frequencies from 9 kHz to 2.4 GHz. Output levels from -137 dBm to +25 dBm are available. These are C size, 2-slot wide plug-in modules that require a VXI bus mainframe for operation.

The simplified block schematic diagram for the instrument is shown in Fig. 4-1.

Modulation

The carrier frequency can be frequency, phase or amplitude modulated from internal or external sources. The internal source can be the sum of two signals and used in combination with an external source connected to the front panel EXT MOD INPUT connector.

Frequency generation

A voltage controlled oscillator (VCO) covering the frequency range 400 to 533 MHz is phase locked to a 10 MHz temperature controlled crystal oscillator using a fractional-N synthesizer system. Additional frequency coverage is achieved by means of frequency division and multiplication. Low frequencies are generated by a beat frequency oscillator (BFO) system.

Control

Internal control of the instrument is achieved by a microprocessor which receives data and sends instructions via an internal 8-bit data bus to the signal processing circuits.

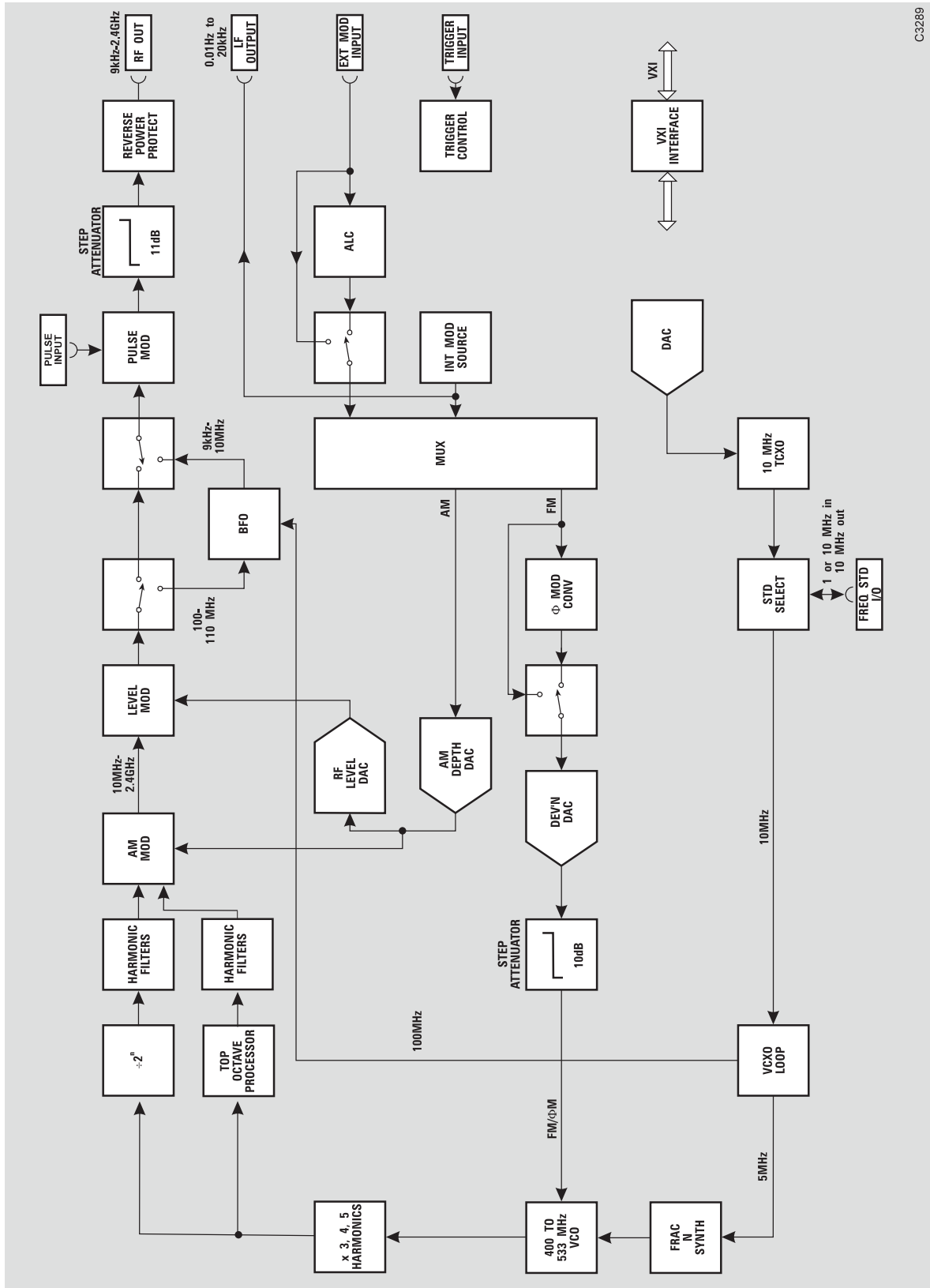

C3289

Fig. 4-1 Block schematic diagram

Chapter 5

ACCEPTANCE TESTING

Contents

Introduction	5-3
Test precautions	5-3
Recommended test equipment	5-4
Executable soft front panel software	5-4
TEST PROCEDURES.....	5-5
RF output	5-5
RF level frequency response	5-6
ALC linearity	5-6
Attenuator accuracy	5-7
Carrier frequency accuracy	5-8
Spectral purity	5-9
Harmonics	5-10
Non-harmonics	5-11
Residual FM	5-11
SSB phase noise	5-12
Internal FM	5-13
FM deviation and distortion	5-14
FM scale shape	5-14
Carrier error	5-15
External FM frequency response (ALC off, DC coupled)	5-15
External FM frequency response (ALC on)	5-16
Phase modulation	5-17
Phase modulation	5-17
Phase modulation flatness	5-17
Amplitude modulation	5-18
AM depth and distortion	5-18
AM scale shape	5-19
External AM frequency response (ALC off, DC coupled)	5-19
Pulse modulation	5-21
Pulse modulation RF level frequency response	5-21
Pulse modulation on/off ratio	5-21
Pulse modulation rise and fall time	5-22
Modulation oscillator	5-22
Modulation oscillator frequencies	5-23
Modulation oscillator distortion and LF output flatness	5-24
External frequency standard input	5-24

List of tables

Table 5-1 RF output at 0 dBm	5-26
Table 5-2 RF output at +7 dBm	5-27
Table 5-3 RF output at +13 dBm	5-28
Table 5-4 RF output at +25 dBm	5-29
Table 5-5 ALC linearity at 2.5 MHz	5-30
Table 5-6 ALC linearity at 500 MHz	5-31
Table 5-7 ALC linearity at 2400 MHz	5-32
Table 5-8 Attenuator test at 2.6 MHz	5-33
Table 5-9 Attenuator test at 540 MHz	5-33

Table 5-10	Attenuator test at 1140 MHz.....	5-34
Table 5-11	Attenuator test at 1740 MHz.....	5-34
Table 5-12	Attenuator test at 2400 MHz.....	5-35
Table 5-13	Alternative attenuator functional test at 10 MHz	5-35
Table 5-14	Carrier frequency tests	5-36
Table 5-15	Carrier harmonic tests at -4 dBm	5-37
Table 5-16	Carrier harmonic tests at 0 dBm	5-38
Table 5-17	Carrier harmonic tests at +7 dBm	5-39
Table 5-18	Carrier harmonic tests at +13 dBm	5-40
Table 5-19	Carrier harmonic tests at +19 dBm	5-41
Table 5-20	Carrier non-harmonic tests.....	5-42
Table 5-21	Residual FM test.....	5-42
Table 5-22	SSB phase noise test	5-42
Table 5-23	Internal FM deviation and distortion tests at 100 kHz deviation	5-43
Table 5-24	FM scale shape tests at 15 MHz carrier	5-44
Table 5-25	Carrier error test at 1.2 GHz, FM deviation 100 kHz	5-44
Table 5-26	External FM frequency response (ALC off, DC coupled), 50 kHz deviation	5-44
Table 5-27	External FM frequency response (ALC on), 10 kHz deviation, 0.75 V input.....	5-45
Table 5-28	External FM frequency response (ALC on), 10 kHz deviation, 1.25 V input.....	5-45
Table 5-29	Internal Φ M and distortion test at 10.5 MHz carrier, 10 rad deviation.....	5-45
Table 5-30	Internal Φ M flatness test.....	5-46
Table 5-31	Internal AM depth and distortion tests at -4 dBm.....	5-46
Table 5-32	Internal AM depth and distortion tests at 0 dBm	5-47
Table 5-33	Internal AM depth and distortion tests at +7 dBm.....	5-47
Table 5-34	AM scale shape test	5-48
Table 5-35	External AM frequency response (ALC off, DC coupled), RF level -4 dBm	5-49
Table 5-36	External AM frequency response (ALC off, DC coupled), RF level +7 dBm	5-49
Table 5-37	Pulse modulation RF output at -7 dBm.....	5-50
Table 5-38	Pulse modulation RF output at +4 dBm.....	5-51
Table 5-39	Pulse modulation on/off ratio test	5-52
Table 5-40	Pulse modulation rise and fall time test	5-52
Table 5-41	Modulation oscillator frequency tests	5-52
Table 5-42	Modulation oscillator distortion and LF output tests	5-53
Table 5-43	External frequency standard tests.....	5-53

List of figures

Fig. 5-1	RF output test set-up.....	5-6
Fig. 5-2	RF output test set-up.....	5-7
Fig. 5-3	Carrier frequency accuracy test set-up.....	5-9
Fig. 5-4	Carrier harmonics and non-harmonics test set-up.....	5-10
Fig. 5-5	Residual FM test set-up	5-11
Fig. 5-6	SSB phase noise test set-up	5-12
Fig. 5-7	Internal modulation and modulation distortion test set-up	5-14
Fig. 5-8	External modulation and modulation distortion test set-up	5-15
Fig. 5-9	0 Hz External AM and distortion test set-up	5-20
Fig. 5-10	Pulse modulation rise and fall time test set-up	5-22
Fig. 5-11	Modulation oscillator frequency test set-up.....	5-23
Fig. 5-12	Modulation oscillator distortion test set-up	5-24
Fig. 5-13	External standard test set-up.....	5-25

Introduction

The test procedures in this chapter enable you to verify that the electrical performance of the signal generator complies with the Performance Data given in Chapter 1. For convenience, the test equipment and specification for each test are summarized before the test procedure.

Apart from the UUT, (Unit Under Test), no specific set-up procedures will be included for the test equipment unless the measurement is dependent on specific instrument settings or special measurement techniques.

Test precautions

To ensure minimum errors and uncertainties when making measurements, it is important to observe the following precautions:-

- (1) Always use recently calibrated test equipment, with any correction figures taken into account, so as to establish a known traceable limit of performance uncertainty. This uncertainty must be allowed for in determining the accuracy of measurements.
- (2) A common external frequency standard, with an accuracy of ± 1 part in 10^9 should be used for any frequency controlled test equipment.
- (3) Use the shortest possible connecting leads.
- (4) Some areas of the specification which are labelled *typical* rather than having clearly defined limits are *not* tested.

Recommended test equipment

The GPIB test equipment recommended for acceptance testing is shown below. Alternative GPIB equipment or VXI equivalent product, may be used provided they comply with the stated minimum specification.

Recommended test equipment

Description	Minimum specification	Example
Power meter	± 0.1 dB from 9 kHz to 2.4 GHz	*IFR 6960B with 6932 sensor
Measuring receiver	0 dBm to -127 dBm; 2.5 MHz to 2.4 GHz Capable of measuring residual FM less than 2 Hz and SSB phase noise < -124 dBc/Hz at 20 kHz offset from a 1 GHz carrier	HP 8902A with option 037 ** and 11722A sensor and 11793A down converter #
Signal generator	+8 dBm from 32.5 MHz to 2.43 GHz	*IFR 2041
Frequency counter	10 Hz to 2.4 GHz	Racal 1999
Audio analyzer	Capable of measuring THD of 0.01% from 100 Hz to 20 kHz	Rhode & Schwarz UPA3
Spectrum analyzer	DC to 7.2 GHz, 3 Hz resolution bandwidth	*IFR 2386
Modulation meter	AM, FM and Φ M 50 kHz to 2.4 GHz, Accuracy $\pm 1\%$ at 1 kHz modulation frequency	*IFR 2305 plus distortion option ***
Function generator	DC to 100 kHz sine, ± 0.6 dB flatness, 100 kHz square wave	HP 3325B
Digital voltmeter	DC voltage measurement	Solartron 7150+
50 Ω load (termination)	1 W, 50 Ω nominal impedance, DC to 2.4 GHz	Lucas Weinschel M1404N
Oscilloscope	100 MHz bandwidth	Tektronix TAS 465
Personal Computer with Microsoft Windows version 3.1 (or greater) installed and fitted with National Instruments PCIIA GPIB Interface Card Racal Instruments 1261A/B VXI Mainframe Racal Instruments 1260-00C GPIB Slot 0 3271 VXI plug & play Install Disk		

*IFR Ltd was previously known as Marconi Instruments Ltd

** Option 037 is necessary to measure SSB phase noise.

If the receiver and down converter are not available, an alternative procedure to ensure attenuator pad accuracy using a power meter is given.

*** The distortion option of the 2305 Modulation Meter allows modulation distortion tests to be carried out with greater ease. If a 2305 with the distortion option is not available, the audio analyzer may be connected to the modulation meter LF output and set to measure distortion.

Executable soft front panel software

The acceptance test procedures use the supplied executable soft front panel as the user interface for the 3271 VXI Signal Generator.

Test procedures

Each test procedure relies on the UUT being set to its power-up conditions. Reset the UUT after each test procedure by setting:

Store/Recall Address 999
Recall

At the end of this chapter are a set of results tables which give all the test points for each of the tests. These tables should be photocopied and used to record the results of all the measurements taken.

RF output

Specification

Level range:	-137 dBm to +25 dBm for carrier frequencies up to 1.2 GHz -137 dBm to +19 dBm for carrier frequencies above 1.2 GHz
Accuracy:	For output levels above -127 dBm and over a temperature range of 17°C to 27°C: <div style="text-align: center;">±1 dBm to 1.2 GHz ±2 dBm to 2.4 GHz</div> Temperature coefficient <±0.02 dB/°C to 1.2 GHz and <±0.04dB/°C to 2.4 GHz
Output impedance:	50 Ω VSWR <1.3:1 to 1.2 GHz <1.5:1 to 2.4 GHz

Test equipment

Description	Minimum specification	Example
Power meter	±0.1 dB from 9 kHz to 2.4 GHz	IFR 6960B and 6932
Measuring receiver	0 dBm to -127 dBm; 2.5 MHz to 2.4 GHz	HP 8902A with 11722A sensor and 11793A down converter
Signal generator	+8 dBm from 32.5 MHz to 2.43 GHz	IFR 2041

ACCEPTANCE TESTING

RF level frequency response

Test procedure

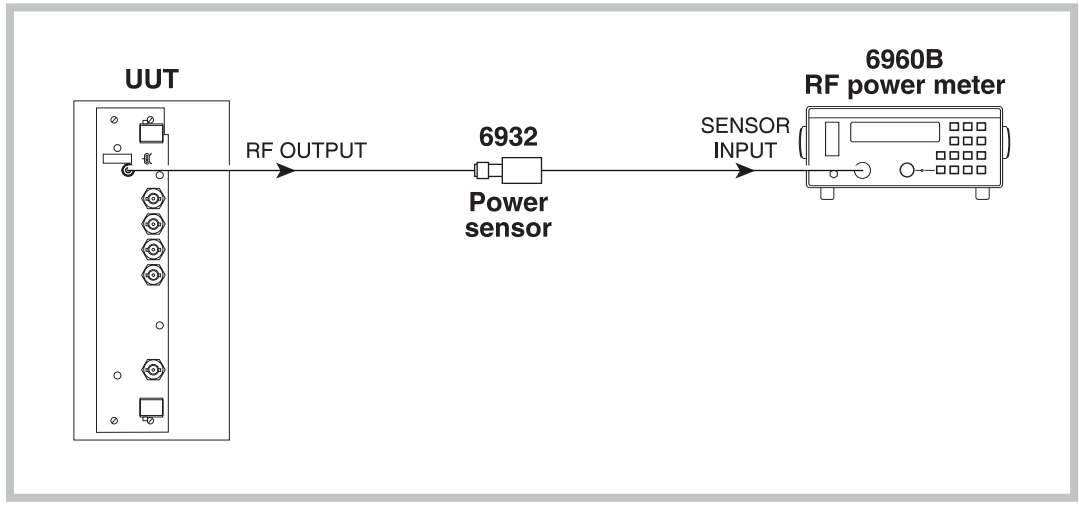

C2926

Fig. 5-1 RF output test set-up

- (1) Perform AUTO ZERO and AUTO CAL on the power meter.
- (2) Connect the test equipment as shown in Fig. 5-1.
- (3) On the UUT set:

Carr Freq	30 kHz
RF Level	0 dBm
- (4) Record the output level measured by the power meter against each of the carrier frequencies shown in Table 5-1 checking that the results are within specification.
- (5) Set the UUT RF level to +7 dBm and repeat (4) using Table 5-2.
- (6) Set the UUT RF level to +13 dBm and repeat (4) using Table 5-3.
- (7) Set the UUT RF level to +25 dBm and repeat (4) using Table 5-4, decreasing the RF level to +19 dBm when testing at carrier frequencies above 1.2 GHz.

ALC linearity

Test procedure

- (1) Perform AUTO ZERO and AUTO CAL on the power meter.
- (2) Connect the test equipment as shown in Fig. 5-1.
- (3) On the UUT set:

Carr Freq	2.5 MHz
RF Level	-4 dBm
- (4) Record the output level measured by the power meter against each of the steps shown in Table 5-5 checking that the results are within specification.
- (5) Set the UUT carrier frequency to 500 MHz and repeat (4) using Table 5-6.
- (6) Set the UUT carrier frequency to 2400 MHz and repeat (4) using Table 5-7.

Attenuator accuracy

The following test will confirm that the attenuator performs to the published performance specification. In the event of the receiver/down-converter not being available, an alternative method to functionally test the individual pads is also suggested (see 'Alternative attenuator functional test' below).

Test procedure

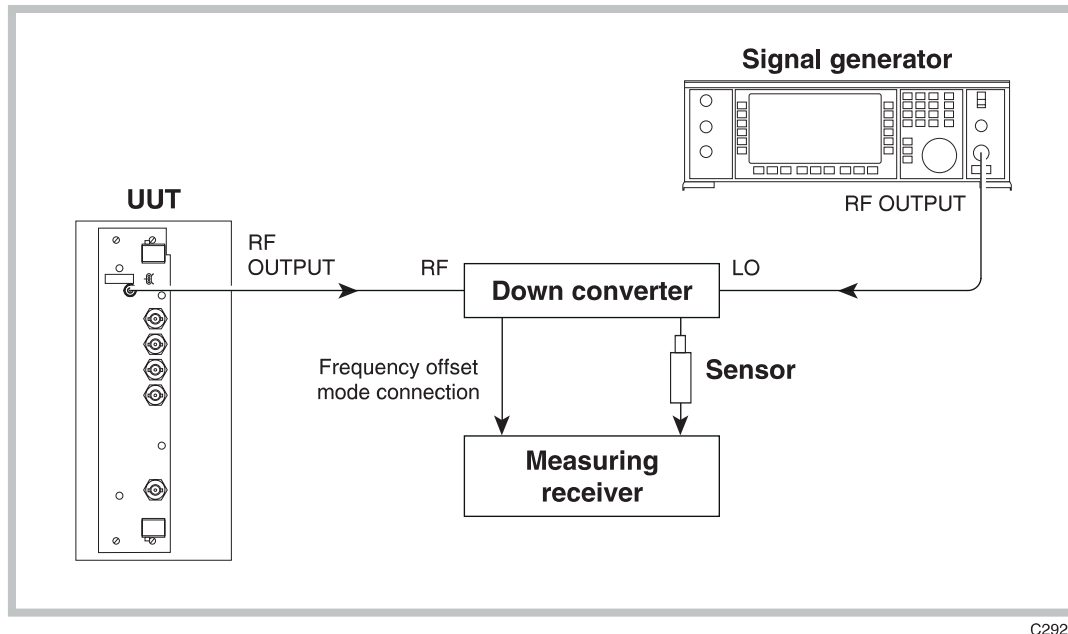

Fig. 5-2 RF output test set-up

- (1) Connect the test equipment as shown in Fig. 5-2.
- (2) On the UUT set:

Carr freq	2.6 MHz
RF Level	0 dBm
Set Δ	11 ENTER
- (3) Tune the receiver to 2.6 MHz and record the output level measured in Table 5-8 checking that the result is within specification.
- (4) Set the UUT RF level to -4.1 dBm. Measure the received level and record the result in Table 5-8 checking that the result is within specification.
- (5) Decrement the UUT, using the ↓ icon, in 11 dB steps down to an RF level of -103.1 dBm measuring the received level at each step shown in Table 5-8 checking that the results are within specification.
- (6) Set the UUT to carrier frequency 540 MHz and repeat (2) to (5) using Table 5-9.
- (7) Set the UUT to carrier frequency 1140 MHz and repeat (2) to (5) using Table 5-10.

The down converter will automatically be enabled when testing frequencies above 1300 MHz.

- (8) Set the local oscillator to +8 dBm at a carrier frequency of 62 MHz less than the test frequency (*i.e.* 1078 MHz).
- (9) On the receiver, enter the local oscillator frequency followed by the test frequency.
- (10) Set the UUT to carrier frequency 1740 MHz and repeat (2) to (5) using Table 5-11.
- (11) Set the UUT to carrier frequency 2400 MHz and repeat (2) to (5) using Table 5-12.

Alternative attenuator functional test

- (1) Connect the test equipment as shown in Fig. 5-1.
- (2) Perform AUTO ZERO and AUTO CAL on the power meter.
- (3) On the UUT set:

Carr Freq	10 MHz
RF Level	13 dBm
Latch	
- (4) Select *RF Board Shift-Reg 1*.
- (5) Select *DATA(binary)*:
- (6) Set a reference on the power meter such that 0 dB is indicated.
- (7) Set the binary data MSB to 0 by sending data word 01111111 (this will enable the first 33 dB pad).
- (8) Record the relative level measured on the power meter in Table 5-13.

Note that this is a nominal value as no software correction figures are applied to the attenuator when performing this test.

- (9) On the UUT, press 1 to disable the first 33 dB pad.
- (10) Repeat (6) to (9) for the next four MSBs; the 22 dB, 33 dB, 11 dB and 33 dB pads respectively.

Carrier frequency accuracy

This check provides a conventional method of checking the signal generator frequency locking circuitry. It will confirm correct operation of phase locked loops and dividers. Overall accuracy is determined by the instrument's internal reference standard.

Specification

Frequency range:	9 kHz to 2.4 GHz
Accuracy:	Determined by the frequency standard accuracy
Resolution:	1 Hz

Test equipment

Description	Minimum specification	Example
Frequency counter	9 kHz to 2.4 GHz	Racal 1999
50 Ω load (termination)	1 W, 50 Ω nominal impedance, DC to 2.4 GHz	Lucas Weinschel M1404N

Test procedure

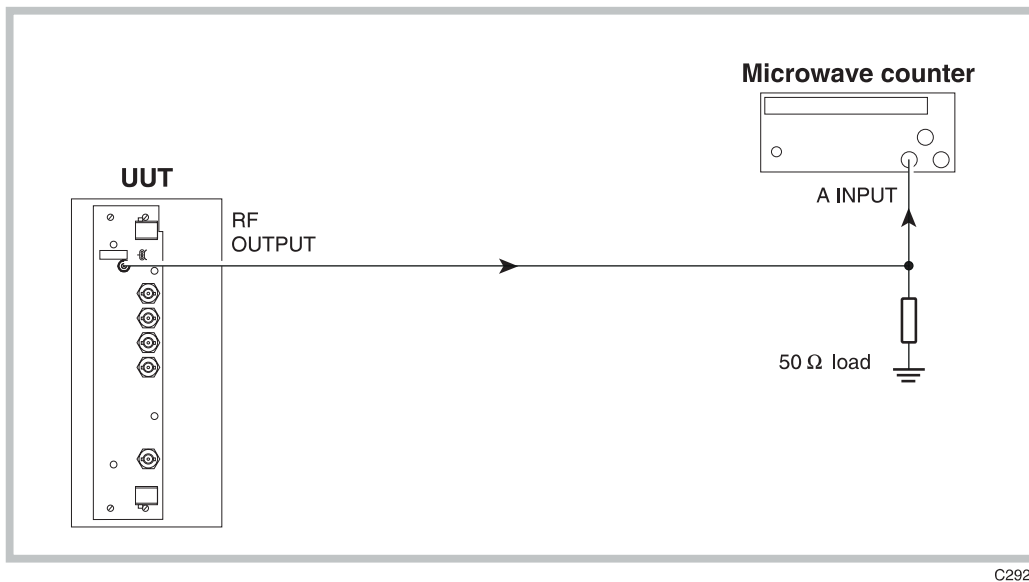

Fig. 5-3 Carrier frequency accuracy test set-up

- (1) Connect the test equipment as shown in Fig. 5-3.
- (2) Connect the internal frequency standard from the UUT to the external standard input on the counter.
- (3) On the UUT set:

Carr Freq	9 kHz
RF Level	0 dBm
- (4) Record the frequency measured by the counter against each of the carrier frequencies shown in Table 5-14. (Since the two instruments' frequencies are locked together, the limit is ± 1 digit on the counter display.)
- (5) At 1200 MHz disconnect the UUT internal frequency standard from the counter and instead apply the external reference. Check the result against the limits.

The test limits quoted are for guidance and assume that the internal frequency standard has recently been adjusted. Aging and stability have to be considered when establishing the *real* test limits (see 'Performance data' in Chapter 1).

It will be necessary to disconnect the 50 Ω load and reconnect the UUT RF OUTPUT socket to the B input where necessary.

ACCEPTANCE TESTING

Spectral purity

Specification

Harmonics:	Typically better than -30 dBc for RF levels up to +7 dBm. Typically -25 dBc for RF levels up to +13 dBm Typically better than -25 dBc for RF levels 6 dB below the maximum specified output
Non-harmonics:	Better than -70 dBc for carrier frequencies up to 1 GHz Better than -64 dBc for carrier frequencies above 1 GHz Better than -60 dBc for carrier frequencies above 2 GHz
Residual FM:	Less than 4.5 Hz RMS in a 300 Hz to 3.4 kHz bandwidth at a carrier frequency of 1 GHz
SSB phase noise:	Better than -121 dBc/Hz at 20 kHz offset from a 470 MHz carrier Typically less than -121 dBc/Hz at 20 kHz offset from a 1 GHz carrier

Test equipment

Description	Minimum specification	Example
Spectrum analyzer	DC to 7.2 GHz frequency coverage	IFR 2386
Measuring receiver	0 dBm to -127 dBm; 2.5 MHz to 2.4 GHz Capable of measuring residual FM less than 2 Hz and SSB phase noise <-124 dBc/Hz at 20 kHz offset from a 1 GHz carrier	HP 8902A with option 037
Signal generator	+8 dBm from 32.5 MHz to 2.43 GHz	IFR 2041
50 Ω load	1 W, 50 Ω nominal impedance, DC to 2.4 GHz	Lucas Weinschel M1404N

Harmonics

Test procedure

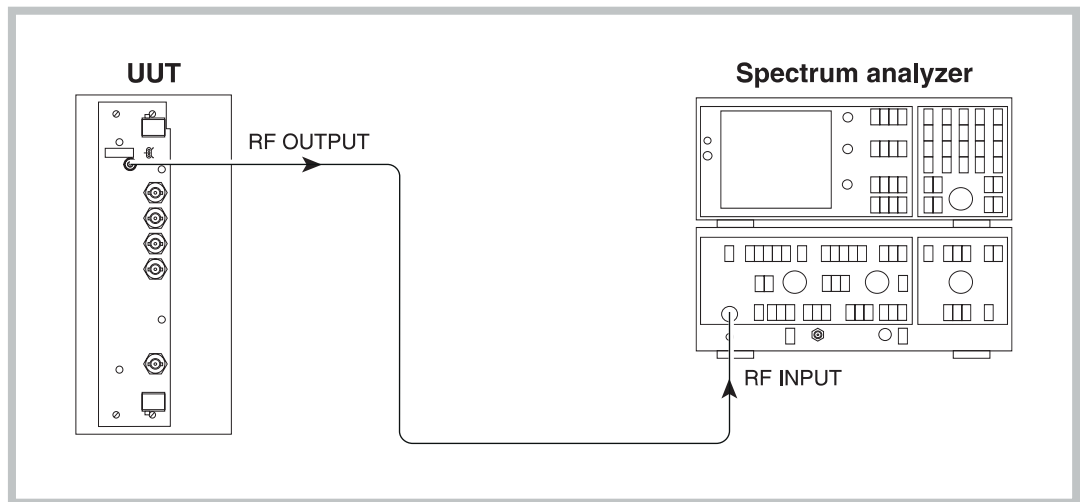

C2929

Fig. 5-4 Carrier harmonics and non-harmonics test set-up

- (1) Press CAL on the spectrum analyzer.
- (2) Connect the test equipment as shown in Fig. 5-4.
- (3) On the UUT set:

Carr Freq	10 kHz
RF Level	-4 dBm
- (4) Measure the level of the second and third harmonics on the spectrum analyzer at each of the carrier frequencies shown in Table 5-15 checking that the results are within specification.
- (5) Set the UUT RF level to 0 dBm and repeat (4) using Table 5-16.
- (6) Set the UUT RF level to +7 dBm and repeat (4) using Table 5-17.
- (7) Set the UUT RF level to +13 dBm and repeat (4) using Table 5-18.
- (8) Set the UUT RF level to +19 dBm and repeat (4) up to 1.2 GHz using Table 5-19.

Non-harmonics

Test procedure

- (1) Press CAL on the spectrum analyzer.
- (2) Connect the test equipment as shown in Fig. 5-4.
- (3) On the UUT set:

Carr Freq	1201 MHz
RF Level	0 dB
- (4) Measure the level of the non-harmonics on the spectrum analyzer at each of the carrier frequencies shown in Table 5-20 checking that the results are within specification.

Residual FM

Test procedure

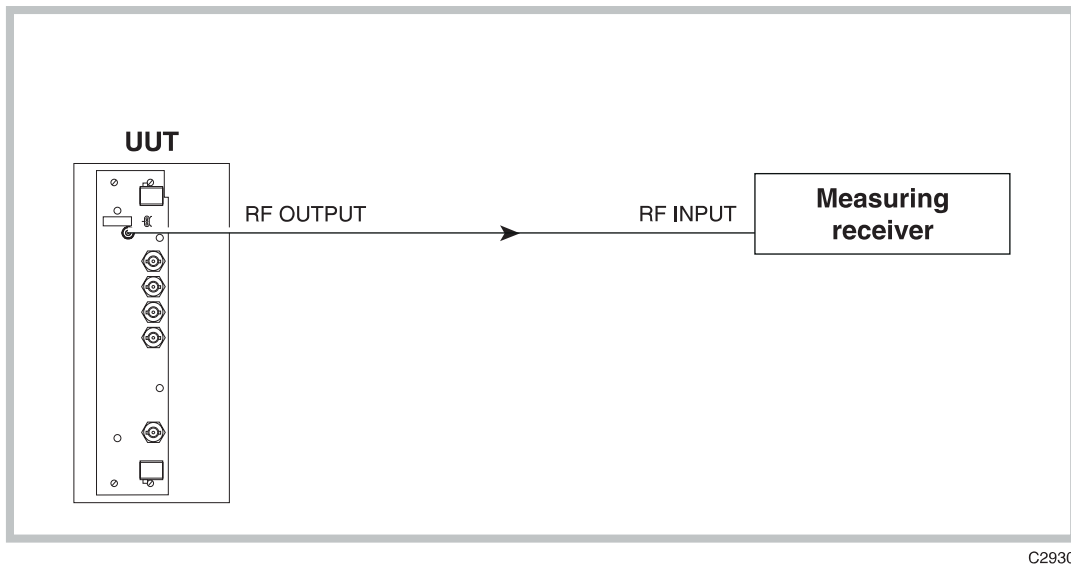

Fig. 5-5 Residual FM test set-up

- (1) Connect the test equipment as shown in Fig. 5-5.
- (2) On the UUT set:

Carr Freq	1 [GHz]
RF Level	0 dBm
- (3) On the measuring receiver select FM, 300 Hz high-pass filter, 3.4 kHz low-pass filter and enable averaging.
- (4) Measure the residual FM checking that the result is within the specification shown in Table 5-21.

SSB phase noise

Test procedure

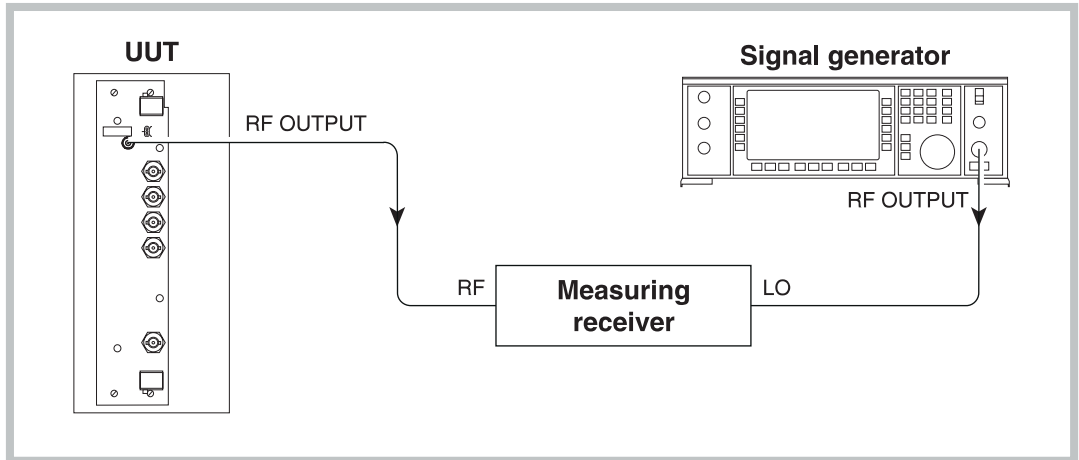

C2931

Fig. 5-6 SSB phase noise test set-up

- (1) Connect the test equipment as shown in Fig. 5-6.
- (2) On the UUT set:

Carr Freq	470 MHz
RF Level	0 dBm
- (3) On the measuring receiver:
 - Tune the receiver to 470 MHz.
 - Select 24.0 SPCL to enter selective power measurement mode.
 - Select 23.1 SPCL to set the LO to external.
- (4) Set the signal generator to a carrier frequency of 470.455 MHz, RF level 0 dBm.
- (5) On the measuring receiver:
 - Select 24.5 SPCL to establish the IF reference value (in volts).
 - Select 24.6 SPCL to set the reference to 0 dBm.
- (6) Fine tune the signal generator frequency until a maximum value is displayed on the measuring receiver.
- (7) On the measuring receiver:
 - Reselect 24.5 SPCL to establish the IF reference value (in volts).
 - Reselect 24.6 SPCL to set the reference to 0 dBm.
 - Select 24.7 SPCL to normalize the measurement for a 1 Hz bandwidth.
- (8) Offset the signal generator by 20 kHz.
- (9) Measure the level on the receiver (the SSB phase noise in a 1 Hz bandwidth) checking that the result is within the specification shown in Table 5-22.

Internal FM

Specification

Deviation range:	0 to 100 kHz
Resolution:	3 digits or 1 Hz
Bandwidth (1 dB):	DC to 100 kHz (DC coupled) 10 Hz to 100 kHz (AC coupled) 20 Hz to 100 kHz (AC coupled with ALC)
Accuracy:	±5% at 1 kHz modulation rate
Carrier error:	Less than 1% of the set frequency deviation when DC coupled
Distortion:	Less than 3% at 1 kHz rate for deviations up to 100 kHz. Typically 0.5% at 1 kHz rate for deviations up to 10 kHz
External modulation input:	1 V RMS for set deviation
Modulation ALC:	Levels the applied external modulation over the range 0.75 to 1.25 V RMS.
FSK:	Accepts logic level inputs (1 or 2) to produce an unfiltered FSK modulated output

Test equipment

Description	Minimum specification	Example
Modulation meter	FM accuracy ±1% at 1 kHz modulation frequency	IFR 2305 with distortion option
DVM	DC voltage measurement	Solartron 7150+
50 Ω load (termination)	1 W, 50 Ω nominal impedance, DC to 2.4 GHz	Lucas Weinschel M1404N
Audio analyser	Capable of measuring THD of 0.01% from 100 Hz to 20 kHz	Rhode & Schwarz UPA3
Function generator	DC to 100 kHz sine, ±0.6 dB flatness	HP 3325B

ACCEPTANCE TESTING

FM deviation and distortion

Test procedure

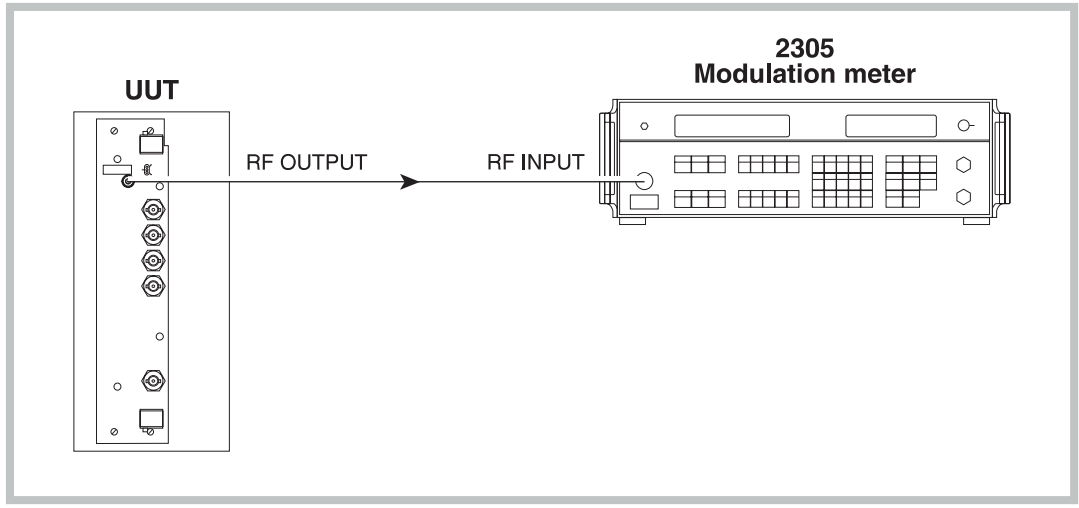

C2932

Fig. 5-7 Internal modulation and modulation distortion test set-up

- (1) Connect the test equipment as shown in Fig. 5-7.
- (2) On the UUT set:

Carr Freq	10 MHz
RF Level	0 dBm
FM1 Level	100 kHz
Mod On	
Source On	
- (3) On the modulation meter select CAL, FM, 50 Hz \Rightarrow 15 kHz filter.
- (4) Measure the FM accuracy and distortion at the carrier frequencies shown in Table 5-23 checking that the results are within specification.

FM scale shape

Test procedure

- (1) Connect the test equipment as shown in Fig. 5-7.
- (2) On the UUT set:

Carr Freq	15 MHz
RF Level	0 dBm
FM1 Level	100 kHz
Mod On	
Source On	
- (3) On the modulation meter select CAL, FM, 50 Hz \Rightarrow 15 kHz filter.
- (4) Measure the FM accuracy at the deviations shown in Table 5-24 checking that the results are within specification.

Carrier error

Test procedure

- (1) Connect the test equipment as shown in Fig. 5-7.
- (2) On the UUT set:

Carr Freq	1200 MHz
RF Level	0 dBm
- (3) On the modulation meter select CARRIER ERROR. The FREQUENCY display will read 0.00 kHz.
- (4) On the UUT set:

Mod Mode	FM External
FM1 Level	100 kHz

Source On
Mod On
DC coupling
Null DCFM
- (5) On the modulation meter measure the carrier frequency error displayed in the FREQUENCY window checking that the result is within the specification shown in Table 5-25.

External FM frequency response (ALC off, DC coupled)

Test procedure

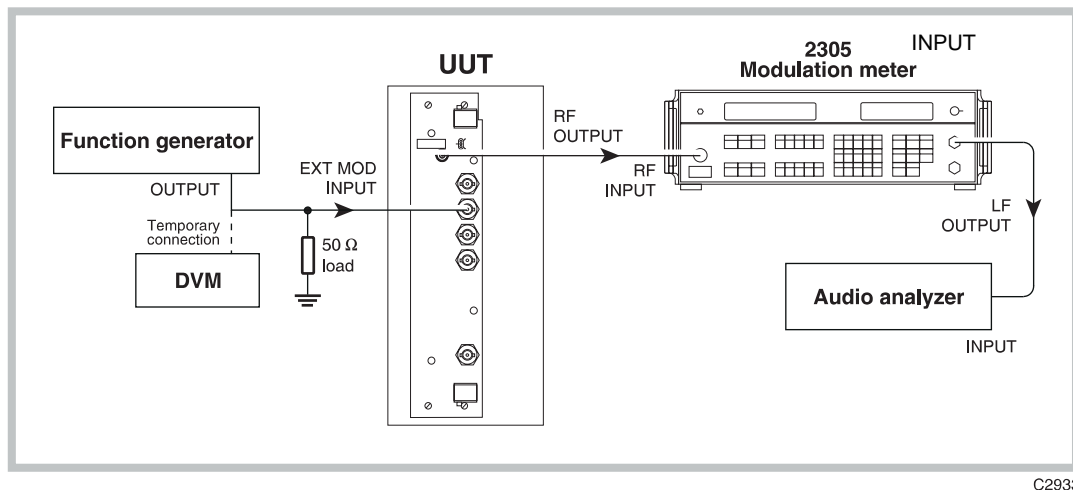

Fig. 5-8 External modulation and modulation distortion test set-up

30 Hz to 100 kHz

- (1) Connect the test equipment as shown in Fig. 5-8.
- (2) On the UUT set:

Carr Freq	15 MHz
RF Level	0 dBm
Mod Mode	FM External
FM1 Level	50 kHz

Source On
Mod On
DC coupling
- (3) Set the function generator to give 1V RMS, 1 kHz sine wave.
- (4) On the modulation meter select CAL, FM, 10 Hz ⇒ 300 kHz filter.

- (5) On the modulation meter check that the FM reading is between 47.5 kHz and 52.5 kHz, then set a reference using the relative function.
- (6) Set the function generator to each of the frequencies shown in Table 5-26 checking that the relative readings on the modulation meter are within specification.
- (7) At those frequencies indicated in Table 5-26, set the modulation meter LF output control to mid-position and measure the AF distortion on the audio analyzer, checking that the results are within specification.

0 Hz (DC)

To measure the FM deviation at DC, it will be necessary to use the DC offset facility on the function generator proceeding as follows:

- (8) Set the function generator to +1.4142 V DC (temporarily connect the function generator output to the DVM and set this voltage as close as possible to +1.4142 V).
- (9) Press CARRIER ERROR on the modulation meter.
- (10) Set the function generator to -1.4142 V DC (temporarily connect the function generator output to the DVM and set this voltage as close as possible to -1.4142 V).
- (11) Measure the frequency indicated on the modulation meter carrier frequency window.

FM1 _____

- (12) Reset the function generator to 1 V RMS, 1 kHz sine wave and measure the FM deviation.

FM2 _____

- (13) Using the following formula, calculate the change in response checking that the result is within the specification shown against 0 Hz in Table 5-26.

$$20 \log_{10} \left\{ \frac{\text{FM2}}{\text{FM1}} \right\}$$

External FM frequency response (ALC on)

Test procedure

- (1) Connect the test equipment as shown in Fig. 5-8.
- (2) On the UUT set:

Carr Freq	15 MHz
RF Level	0 dBm
Mod Mode	FM External
FM1 Level	10 kHz
Source On	
Mod On	
ALC coupling	
- (3) Set the function generator to give 0.75 V RMS, 1 kHz sine wave.
- (4) On the modulation meter select CAL, FM, 10 Hz \Rightarrow 300 kHz filter.
- (5) On the modulation meter check that the FM reading is between 9.5 kHz and 10.5 kHz, then set a reference using the relative function.
- (6) Set the function generator to each of the frequencies shown in Table 5-27 checking that the relative readings on the modulation meter are within specification.
- (7) Set the function generator to 1.25 V RMS and repeat (4) to (6) using Table 5-28, also measuring the AF distortion on the audio analyzer at those frequencies indicated.

Phase modulation

Specification

Range:	0 to 10 radians
Resolution:	3 digits or 0.01 radians
Bandwidth (3 dB):	10 Hz to 10 kHz
Accuracy:	±5% at 1 kHz modulation rate
Distortion:	Less than 3% at 10 radians at 1 kHz modulation rate

Test equipment

Description	Minimum specification	Example
Modulation meter	ΦM and FM accuracy ±2% at 1 kHz modulation frequency	IFR 2305 with distortion option

Phase modulation

Test procedure

- (1) Connect the test equipment as shown in Fig. 5-7.
- (2) On the UUT set:

Carr Freq	10.5 MHz
RF Level	0 dBm
Source On	
Mod Mode	PM Internal
PM1 Level	10 rad
- (3) On the modulation meter, select CAL, ΦM.
- (4) Measure the ΦM accuracy and distortion checking that the results are within the specification shown in Table 5-29.

Phase modulation flatness

Test procedure

For this test, the phase modulation figures are calculated from readings taken with the modulation meter set to FM. No allowances need to be made for the modulation source frequency accuracy since it is derived from the reference oscillator in the UUT.

- (1) Connect the test equipment as shown in Fig. 5-7.
- (2) On the UUT set:

Carr Freq	15 MHz
RF Level	0 dBm
Mod Mode	PM Internal
Source On	
Mod On	
PM1 Level	10 rad
- (3) On the modulation meter, select CAL, FM, 50 Hz ⇒ 15 kHz LF filter.
- (4) Measure the deviation on the modulation meter and calculate the phase modulation using the formula:

$$\Phi M = \left\{ \frac{\text{FM dev (Hz)}}{\text{mod freq (Hz)}} \right\}$$

- (5) On the UUT set mod source to each of the frequencies shown in Table 5-30, measure the deviation on the modulation meter and calculate the phase modulation for each step using the formula in (4).
- (6) Using the figure recorded in (4) as a reference, calculate the change in response at each modulation frequency using the formula:

$$20 \log_{10} \left\{ \frac{\text{Figure recorded in (5)}}{\text{Figure recorded in (4)}} \right\}$$

Check that the results are within the specifications shown in Table 5-30.

Amplitude modulation

Specification

Range:	0 to 99.9%
Resolution:	0.1%
Carrier frequency range:	<500 MHz, usable to 2 GHz
Bandwidth (1 dB):	DC to 30 kHz (DC coupled) 10 Hz to 30 kHz (AC coupled) 20 Hz to 30 kHz (AC coupled with ALC)
Accuracy:	±5% of set depth at 1 kHz modulation rate
Distortion:	For modulation depths up to 80%, less than 2.5% at 1 kHz rate; for modulation depths up to 30%, less than 1.5% at 1 kHz rate.
ΦM on AM:	Typically 0.1 radians at 30% depth at 470 MHz

Test equipment

Description	Minimum specification	Example
Modulation meter	AM accuracy ±1% at 1 kHz modulation frequency	IFR 2305 with distortion option
DVM	DC voltage measurement	Solartron 7150+
50 Ω load (termination)	1 W 50 Ω nominal impedance, DC to 2.4 GHz	Lucas Weinschel M1404N
Audio analyser	Capable of measuring THD of 0.01% from 100 Hz to 20 kHz	Rhode & Schwarz UPA3
Function generator	DC to 30 kHz sine, ±0.6 dB flatness	HP 3325B

AM depth and distortion

Test procedure

- (1) Connect the test equipment as shown in Fig. 5-7.
- (2) On the UUT set:

Carr Freq	1.5 MHz
RF Level	-4 dBm
Mod Mode	AM Internal
Source On	
Mod On	
AM1 Level	30%
- (3) On the modulation meter, select CAL, AM, 300 Hz ⇒ 3.4 kHz LF filter.

- (4) Measure the AM accuracy and distortion at the frequencies shown in Table 5-31 checking that the results are within specification.
- (5) Set the UUT AM1 level to 80% and repeat (4).
- (6) Set the UUT to RF level 0 dBm and repeat (2) to (5) using Table 5-32.
- (7) Set the UUT to RF level +7 dBm and repeat (2) to (5) using Table 5-33.

AM scale shape

Test procedure

- (1) Connect the test equipment as shown in Fig. 5-7.
- (2) On the UUT set:

Carr Freq	100 MHz
RF Level	0 dBm
Mod Mode	AM Internal
Source On	
Mod On	
AM1 Level	30%
- (3) On the modulation meter, select CAL, AM, 300 Hz \Rightarrow 3.4 kHz LF filter.
- (4) Measure the AM accuracy at the depths shown in Table 5-34 checking that the results are within specification.

External AM frequency response (ALC off, DC coupled)

Test procedure

100 Hz to 30 kHz

- (1) Connect the test equipment as shown in Fig. 5-8.
- (2) On the UUT set:

Carr Freq	400 MHz
RF Level	-4 dBm
Mod Mode	AM External
AM1 Level	80%
Source On	
Mod On	
DC coupling	
- (3) Set the function generator to give 1 V RMS, 1 kHz sine wave.
- (4) On the modulation meter select CAL, AM, 10 Hz \Rightarrow 300 kHz filter.
- (5) On the modulation meter check that the AM reading is between 76% and 84%, then set a reference using the relative function.
- (6) Record the absolute reading for use in the formula in (16) below.
- (7) Set the function generator to each of the frequencies shown in Table 5-35 checking that the relative readings on the modulation meter are within specification.
- (8) Set the UUT RF level to +7 dBm and repeat (3) to (7) using Table 5-36.

0 Hz (DC)

To measure the AM depth at DC, it will be necessary to use the DC offset facility on the function generator proceeding as follows:

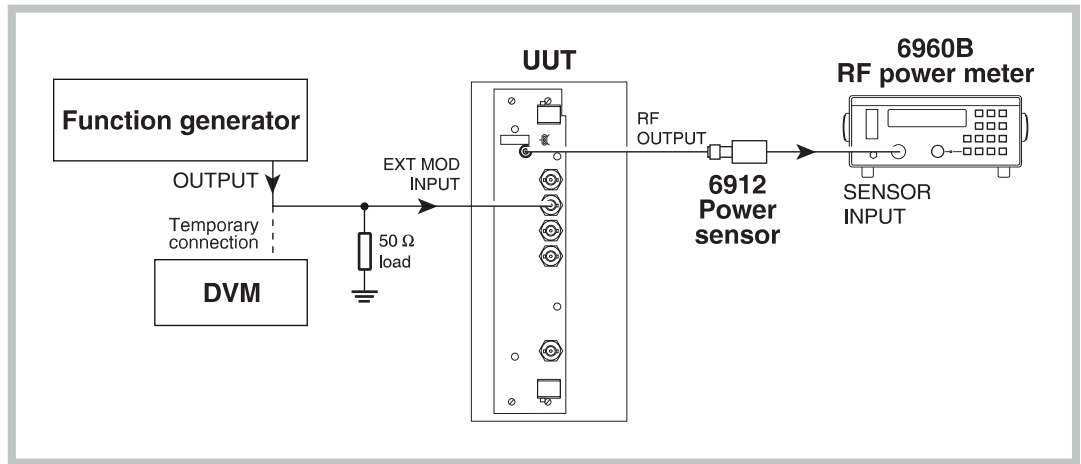

C2934

Fig. 5-9 0 Hz External AM and distortion test set-up

- (9) Connect the test equipment as shown in Fig. 5-9.
- (10) Set the function generator to +1.4142 V DC (temporarily connect the function generator output to the DVM and set this voltage as close as possible to +1.4142 V).
- (11) Measure the power on the power meter.

P1 _____

- (12) Set the function generator to -1.4142 V DC (temporarily connect the function generator output to the DVM and set this voltage as close as possible to -1.4142 V).
- (13) Measure the power on the power meter.

P2 _____

- (14) Subtract P2 from P1 (= x).
- (15) Calculate the modulation depth using the formula:

$$AM(\%) = \left\{ \frac{1 - 10^{(-x/20)}}{1 + 10^{(-x/20)}} \right\}$$

- (16) Calculate the 0 Hz response relative to 1 kHz using the following formula, recording the result in Table 5-35:

$$20 \log_{10} \left\{ \frac{\text{Figure recorded in (6)}}{\text{Figure recorded in (15)}} \right\}$$

- (17) Set the UUT RF level to +7 dBm and repeat (4) to (16) using Table 5-36.

Pulse modulation

Specification

Carrier frequency range:	32 MHz to 2.4 GHz, usable to 10 MHz
RF level range:	Maximum guaranteed output is reduced to +8 dBm when pulse modulation is selected
RF level accuracy:	Maximum additional uncertainty is ± 0.5 dB
On/off ratio:	Better than 40 dB Better than 45 dB below 1.2 GHz
Rise and fall time:	Less than 10 μ s

Test equipment

Description	Minimum specification	Example
Power meter	± 0.1 dB from 9 kHz to 2.4 GHz	IFR 6960B and 6912
Spectrum analyser	Frequency coverage 32 MHz to 2.4 GHz	IFR 2386 or 2383
50 Ω load (termination)	1 W, 50 Ω nominal impedance, DC to 2.4 GHz	Lucas Weinschel M1404N
Oscilloscope	100 MHz bandwidth	Tektronix TAS 465
Function generator	DC to 10 kHz square wave	HP 3325B

Pulse modulation RF level frequency response

Test procedure

- (1) Perform AUTO ZERO and AUTO CAL on the power meter.
 - (2) Connect the test equipment as shown in Fig. 5-1.
 - (3) On the UUT set:

Carr Freq	32 MHz
RF Level	-7 dBm
Pulse ON	
 - (4) Record the output level measured by the power meter against each of the carrier frequencies shown in Table 5-37 checking that the results are within specification.
- Set the UUT RF level to +4 dBm and repeat (4) using Table 5-38.

ACCEPTANCE
TESTING

Pulse modulation on/off ratio

Test procedure

- (1) Press CAL on the spectrum analyzer.
- (2) Connect the test equipment as shown in Fig. 5-4.
- (3) On the UUT set:

Carr Freq	32 MHz
RF Level	0 dBm
Pulse ON	
- (4) Tune the spectrum analyzer to the same frequency as the signal generator.
- (5) Press PEAK FIND on the spectrum analyzer and note the output level.
- (6) Apply a short circuit to the PULSE INPUT socket.
- (7) Again note the output level measured by the spectrum analyzer.

- (8) The difference between the levels recorded in (5) and (7) is the pulse mod on/off ratio. Check that the ratio is within specification using Table 5-39.
- (9) Repeat (4) to (8) for each of the frequencies shown in Table 5-39.

Pulse modulation rise and fall time

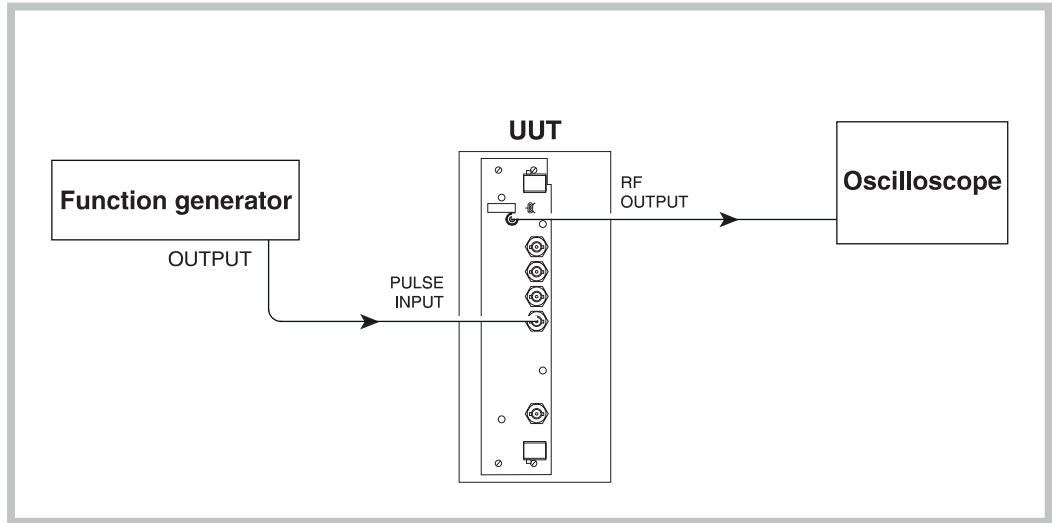

C2935

Fig. 5-10 Pulse modulation rise and fall time test set-up

Test procedure

- (1) Connect the test equipment as shown in Fig. 5-10.
- (2) On the UUT set:

Carr Freq	50 MHz
RF Level	+7 dBm
Pulse ON	
- (3) Set the function generator to produce 10 kHz, 0 V to +5 V square wave.
- (4) Adjust the oscilloscope controls such that the rise time of the envelope can be measured.
- (5) Measure the rise time between the 10% to 90% points checking that it is within the specification shown in Table 5-40.
- (6) Repeat (4) to (5) for the fall time of the envelope.

Modulation oscillator

Specification

Frequency range:	0.01 Hz to 20 kHz
Resolution:	0.01 Hz to 100 Hz 0.1 Hz to 1 kHz 1 Hz to 20 kHz
Distortion:	Less than 0.1% at 1 kHz
Sine wave frequency response:	Typically 1 dB, DC to 20 kHz
Waveforms:	Sine (to 20 kHz), triangle or square wave (to 3 kHz) Square wave jitter <6.4 μ s on any edge
Output:	2 V RMS EMF from a 600 Ω source impedance

Test equipment

Description	Minimum specification	Example
Frequency counter	9 kHz to 2.4 GHz	Racal 1999
50 Ω load (termination)	1 W, 50 Ω nominal impedance, DC to 2.4 GHz	Lucas Weinschel M1404N
Audio analyzer	Capable of measuring THD of 0.01% at 1 kHz	Rohde & Schwarz UPA3

Modulation oscillator frequencies

Test procedure

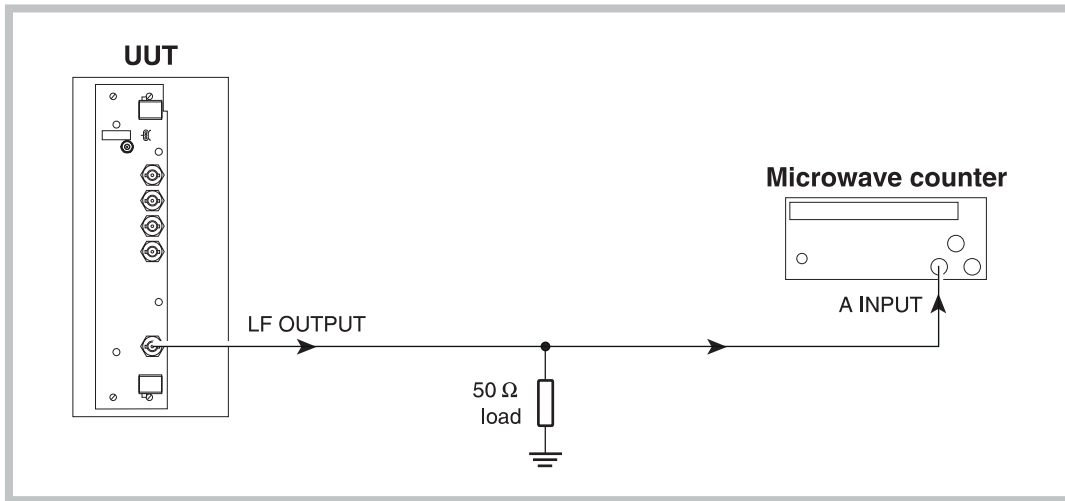

C2936

Fig. 5-11 Modulation oscillator frequency test set-up

- (1) Connect the test equipment as shown in Fig. 5-11.
- (2) On the UUT set:

FM1 Freq	10 Hz
----------	-------
- (3) Record the frequency measured by the counter against each of the modulation oscillator frequencies shown in Table 5-41.

ACCEPTANCE TESTING

Modulation oscillator distortion and LF output flatness

Test procedure

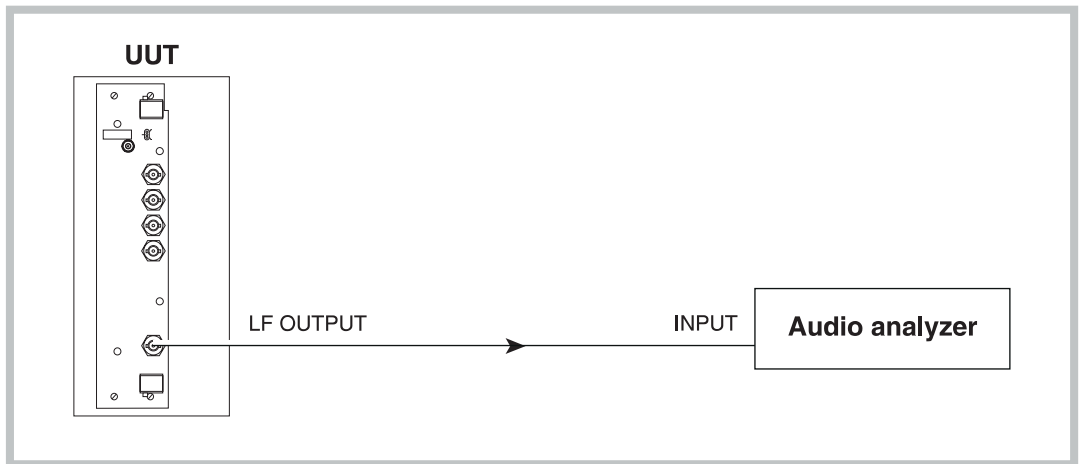

C2937

Fig. 5-12 Modulation oscillator distortion test set-up

- (1) Connect the test equipment as shown in Fig. 5-12.
- (2) On the UUT set:
FM1 Freq 1 kHz
- (3) Measure the distortion on the audio analyzer checking that the result is within the specification shown in Table 5-42.
- (4) Measure the absolute level on the audio analyzer (in dBm) and record this level as a reference.
- (5) Set the UUT mod source to each of the frequencies shown in Table 5-42. Subtract the level measured on the audio analyzer at each frequency from that recorded in (4) checking that the results are within specification.

External frequency standard input

Specification

Input levels:	Requires an input of 220 mV RMS to 1.8 V RMS into 1 k Ω
Input frequencies:	1 MHz or 10 MHz

Test equipment

Description	Minimum specification	Example
Signal generator	220 mV to 1.8 V RMS, 1 MHz to 10 MHz	IFR 2041 or 2030

Test procedure

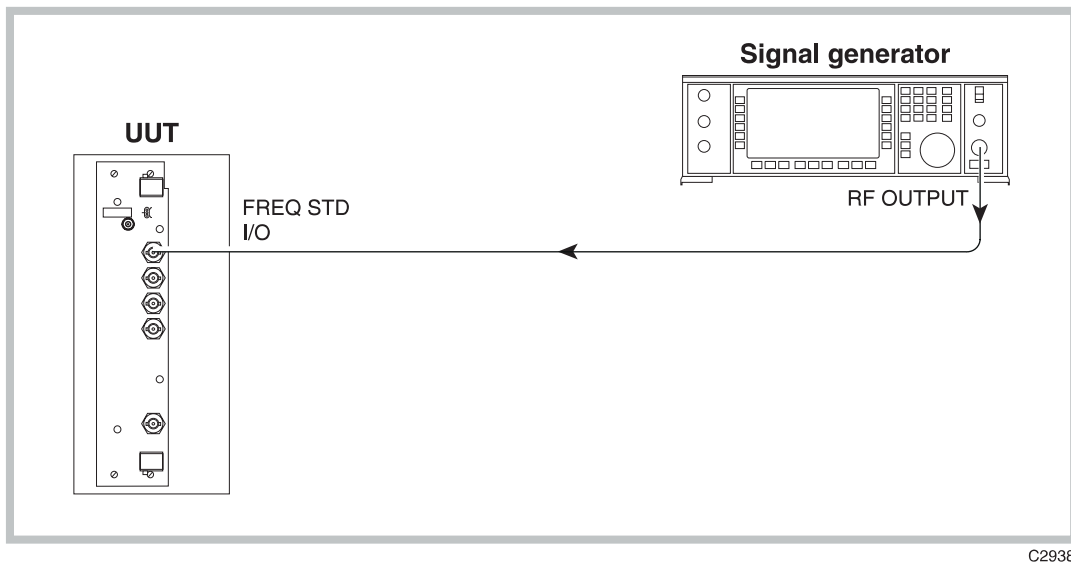

Fig. 5-13 External standard test set-up.

- (1) Connect the test equipment as shown in Fig. 5-13.
- (2) On the UUT set:
Freq Std External 10 Direct
- (3) Set the signal generator to RF level 220 mV EMF, carrier frequency 1 MHz.
- (4) Using Table 5-43, check that no external standard error messages are displayed on the UUT.
- (5) Set the signal generator to 1.8 V EMF and repeat (4).
- (6) On the UUT set
Freq Std External 10 Indirect
- (7) Set the signal generator to carrier frequency 10 MHz and repeat (4).
- (8) Set the signal generator to 220 mV and repeat (4).

ACCEPTANCE
TESTING

ACCEPTANCE TEST RESULTS TABLES

For 3271 Signal Generator, serial number _____ / _____

Table 5-1 RF output at 0 dBm

Carrier frequency (MHz)	RF level min. (dBm)	Result (dBm)	RF level max. (dBm)
0.03	-1	_____	+1
0.33	-1	_____	+1
60	-1	_____	+1
180	-1	_____	+1
300	-1	_____	+1
420	-1	_____	+1
540	-1	_____	+1
660	-1	_____	+1
780	-1	_____	+1
900	-1	_____	+1
1020	-1	_____	+1
1140	-1	_____	+1
1200	-1	_____	+1
1201	-2	_____	+2
1260	-2	_____	+2
1380	-2	_____	+2
1500	-2	_____	+2
1620	-2	_____	+2
1740	-2	_____	+2
1860	-2	_____	+2
1980	-2	_____	+2
2220	-2	_____	+2
2340	-2	_____	+2
2400	-2	_____	+2

Table 5-2 RF output at +7 dBm

Carrier frequency (MHz)	RF level min. (dBm)	Result (dBm)	RF level max. (dBm)
0.03	+6	_____	+8
0.33	+6	_____	+8
60	+6	_____	+8
180	+6	_____	+8
300	+6	_____	+8
420	+6	_____	+8
540	+6	_____	+8
660	+6	_____	+8
780	+6	_____	+8
900	+6	_____	+8
1020	+6	_____	+8
1140	+6	_____	+8
1200	+6	_____	+8
1201	+5	_____	+9
1260	+5	_____	+9
1380	+5	_____	+9
1500	+5	_____	+9
1620	+5	_____	+9
1740	+5	_____	+9
1860	+5	_____	+9
1980	+5	_____	+9
2220	+5	_____	+9
2340	+5	_____	+9
2400	+5	_____	+9

ACCEPTANCE TESTING

Table 5-3 RF output at +13 dBm

Carrier frequency (MHz)	RF level min. (dBm)	Result (dBm)	RF level max. (dBm)
0.03	+12	_____	+14
0.33	+12	_____	+14
60	+12	_____	+14
180	+12	_____	+14
300	+12	_____	+14
420	+12	_____	+14
540	+12	_____	+14
660	+12	_____	+14
780	+12	_____	+14
900	+12	_____	+14
1020	+12	_____	+14
1140	+12	_____	+14
1200	+12	_____	+14
1201	+11	_____	+15
1260	+11	_____	+15
1380	+11	_____	+15
1500	+11	_____	+15
1620	+11	_____	+15
1740	+11	_____	+15
1860	+11	_____	+15
1980	+11	_____	+15
2220	+11	_____	+15
2340	+11	_____	+15
2400	+11	_____	+15

Table 5-4 RF output at +25 dBm

Carrier frequency (MHz)	RF level min. (dBm)	Result (dBm)	RF level max. (dBm)
0.03	+24	_____	+26
0.33	+24	_____	+26
60	+24	_____	+26
180	+24	_____	+26
300	+24	_____	+26
420	+24	_____	+26
540	+24	_____	+26
660	+24	_____	+26
780	+24	_____	+26
900	+24	_____	+26
1020	+24	_____	+26
1140	+24	_____	+26
1200	+24	_____	+26
+19 dBm			
1201	+17	_____	+21
1260	+17	_____	+21
1380	+17	_____	+21
1500	+17	_____	+21
1620	+17	_____	+21
1740	+17	_____	+21
1860	+17	_____	+21
1980	+17	_____	+21
2220	+17	_____	+21
2340	+17	_____	+21
2400	+17	_____	+21

ACCEPTANCE TESTING

Table 5-5 ALC linearity at 2.5 MHz

RF level (dBm)	RF level min. (dBm)	Result (dBm)	RF level max. (dBm)
-4	-5	_____	-3
3	-4	_____	-2
-2	-3	_____	-1
-1	-2	_____	0
0	-1	_____	+1
1	0	_____	+2
2	+1	_____	+3
3	+2	_____	+4
4	+3	_____	+5
5	+4	_____	+6
6	+5	_____	+7
7	+6	_____	+8
8	+7	_____	+9
9	+8	_____	+10
10	+9	_____	+11
11	+10	_____	+12
12	+11	_____	+13
12.1	+11.1	_____	+13.1
12.2	+11.2	_____	+13.2
12.3	+11.3	_____	+13.3
12.4	+11.4	_____	+13.4
12.5	+11.5	_____	+13.5
12.6	+11.6	_____	+13.6
12.7	+11.7	_____	+13.7
12.8	+11.8	_____	+13.8
12.9	+11.9	_____	+13.9
13	+12	_____	+14
14	+13	_____	+15
15	+14	_____	+16
16	+15	_____	+17
17	+16	_____	+18
18	+17	_____	+19
19	+18	_____	+20
20	+19	_____	+21
21	+20	_____	+22
22	+21	_____	+23
23	+22	_____	+24
24	+23	_____	+25
25	+24	_____	+26

Table 5-6 ALC linearity at 500 MHz

RF level (dBm)	RF level min. (dBm)	Result (dBm)	RF level max. (dBm)
-4	-5	_____	-3
-3	-4	_____	-2
-2	-3	_____	-1
-1	-2	_____	0
0	-1	_____	+1
1	0	_____	+2
2	+1	_____	+3
3	+2	_____	+4
4	+3	_____	+5
5	+4	_____	+6
6	+5	_____	+7
7	+6	_____	+8
8	+7	_____	+9
9	+8	_____	+10
10	+9	_____	+11
11	+10	_____	+12
12	+11	_____	+13
12.1	+11.1	_____	+13.1
12.2	+11.2	_____	+13.2
12.3	+11.3	_____	+13.3
12.4	+11.4	_____	+13.4
12.5	+11.5	_____	+13.5
12.6	+11.6	_____	+13.6
12.7	+11.7	_____	+13.7
12.8	+11.8	_____	+13.8
12.9	+11.9	_____	+13.9
13	+12	_____	+14
14	+13	_____	+15
15	+14	_____	+16
16	+15	_____	+17
17	+16	_____	+18
18	+17	_____	+19
19	+18	_____	+20
20	+19	_____	+21
21	+20	_____	+22
22	+21	_____	+23
23	+22	_____	+24
24	+23	_____	+25
25	+24	_____	+26

ACCEPTANCE TESTING

Table 5-7 ALC linearity at 2400 MHz

RF level (dBm)	RF level min. (dBm)	Result (dBm)	RF level max. (dBm)
-4	-6	_____	-2
-3	-5	_____	-1
-2	-4	_____	0
-1	-3	_____	+1
0	-2	_____	+2
1	-1	_____	+3
2	0	_____	+4
3	+1	_____	+5
4	+2	_____	+6
5	+3	_____	+7
6	+4	_____	+8
7	+5	_____	+9
8	+6	_____	+10
9	+7	_____	+11
10	+8	_____	+12
11	+9	_____	+13
12	+10	_____	+14
12.1	+10.1	_____	+14.1
12.2	+10.2	_____	+14.2
12.3	+10.3	_____	+14.3
12.4	+10.4	_____	+14.4
12.5	+10.5	_____	+14.5
12.6	+10.6	_____	+14.6
12.7	+10.7	_____	+14.7
12.8	+10.8	_____	+14.8
12.9	+10.9	_____	+14.9
13	+11	_____	+15
14	+12	_____	+16
15	+13	_____	+17
16	+14	_____	+18
17	+15	_____	+19
18	+16	_____	+20
19	+17	_____	+21

Table 5-8 Attenuator test at 2.6 MHz

RF level (dBm)	RF level min. (dBm)	Result (dBm)	RF level max. (dBm)
0	-1	_____	+1
-4.1	-5.1	_____	-3.1
-15.1	-16.1	_____	-14.1
-26.1	-27.1	_____	-25.1
-37.1	-38.1	_____	-36.1
-48.1	-49.1	_____	-47.1
-59.1	-60.1	_____	-58.1
-70.1	-71.1	_____	-69.1
-81.1	-82.1	_____	-80.1
-92.1	-93.1	_____	-91.1
-103.1	-104.1	_____	-102.1

Table 5-9 Attenuator test at 540 MHz

RF level (dBm)	RF level min. (dBm)	Result (dBm)	RF level max. (dBm)
0	-1	_____	+1
-4.1	-5.1	_____	-3.1
-15.1	-16.1	_____	-14.1
-26.1	-27.1	_____	-25.1
-37.1	-38.1	_____	-36.1
-48.1	-49.1	_____	-47.1
-59.1	-60.1	_____	-58.1
-70.1	-71.1	_____	-69.1
-81.1	-82.1	_____	-80.1
-92.1	-93.1	_____	-91.1
-103.1	-104.1	_____	-102.1

ACCEPTANCE TESTING

Table 5-10 Attenuator test at 1140 MHz

RF level (dBm)	RF level min. (dBm)	Result (dBm)	RF level max. (dBm)
0	-1	_____	+1
-4.1	-5.1	_____	-3.1
-15.1	-16.1	_____	-14.1
-26.1	-27.1	_____	-25.1
-37.1	-38.1	_____	-36.1
-48.1	-49.1	_____	-47.1
-59.1	-60.1	_____	-58.1
-70.1	-71.1	_____	-69.1
-81.1	-82.1	_____	-80.1
-92.1	-93.1	_____	-91.1
-103.1	-104.1	_____	-102.1

Table 5-11 Attenuator test at 1740 MHz

RF level (dBm)	RF level min. (dBm)	Result (dBm)	RF level max. (dBm)
0	-2	_____	+2
-4.1	-6.1	_____	-2.1
-15.1	-17.1	_____	-13.1
-26.1	-28.1	_____	-24.1
-37.1	-39.1	_____	-35.1
-48.1	-50.1	_____	-46.1
-59.1	-61.1	_____	-57.1
-70.1	-72.1	_____	-68.1
-81.1	-83.1	_____	-79.1
-92.1	-94.1	_____	-90.1
-103.1	-105.1	_____	-101.1

Table 5-12 Attenuator test at 2400 MHz

RF level (dBm)	RF level min. (dBm)	Result (dBm)	RF level max. (dBm)
0	-2	_____	+2
-4.1	-6.1	_____	-2.1
-15.1	-17.1	_____	-13.1
-26.1	-28.1	_____	-24.1
-37.1	-39.1	_____	-35.1
-48.1	-50.1	_____	-46.1
-59.1	-61.1	_____	-57.1
-70.1	-72.1	_____	-68.1
-81.1	-83.1	_____	-79.1
-92.1	-94.1	_____	-90.1
-103.1	-105.1	_____	-101.1

Table 5-13 Alternative attenuator functional test at 10 MHz

Attenuator pad	Measured value (dB)
33 dB	_____
22 dB	_____
33 dB	_____
11 dB	_____
33 dB	_____

ACCEPTANCE TESTING

Table 5-14 Carrier frequency tests

Frequency (MHz)	Frequency min. (MHz)	Result (MHz)	Frequency max. (MHz)
0.009	-	_____	-
1	-	_____	-
9.999999	-	_____	-
18.75	-	_____	-
37.5	-	_____	-
75	-	_____	-
150	-	_____	-
300	-	_____	-
600	-	_____	-
1200	1199.99988	_____	1200.00012
1200.000001	-	_____	-
1230	-	_____	-
1250	-	_____	-
1260	-	_____	-
1320	-	_____	-
1350	-	_____	-
1500	-	_____	-
1599.999999	-	_____	-
2400	-	_____	-

Table 5-15 Carrier harmonic tests at -4 dBm

Carrier frequency (MHz)	2nd harmonic max. level (dBc)	Result (MHz)	3rd harmonic max. level (dBc)	Result (MHz)
0.01	-30	_____	-30	_____
0.1	-30	_____	-30	_____
1	-30	_____	-30	_____
9.9	-30	_____	-30	_____
10	-30	_____	-30	_____
18.7	-30	_____	-30	_____
18.8	-30	_____	-30	_____
37.4	-30	_____	-30	_____
37.6	-30	_____	-30	_____
74.9	-30	_____	-30	_____
75.1	-30	_____	-30	_____
150	-30	_____	-30	_____
151	-30	_____	-30	_____
300	-30	_____	-30	_____
301	-30	_____	-30	_____
600	-30	_____	-30	_____
601	-30	_____	-30	_____
750	-30	_____	-30	_____
950	-30	_____	-30	_____
1200	-30	_____	-30	_____
1201	-30	_____	-30	_____
1500	-30	_____	-30	_____
1900	-30	_____	-30	_____
2400	-30	_____	-30	_____

ACCEPTANCE TESTING

Table 5-16 Carrier harmonic tests at 0 dBm

Carrier frequency (MHz)	2nd harmonic max. level (dBc)	Result (MHz)	3rd harmonic max. level (dBc)	Result (MHz)
0.01	-30	_____	-30	_____
0.1	-30	_____	-30	_____
1	-30	_____	-30	_____
9.9	-30	_____	-30	_____
10	-30	_____	-30	_____
18.7	-30	_____	-30	_____
18.8	-30	_____	-30	_____
37.4	-30	_____	-30	_____
37.6	-30	_____	-30	_____
74.9	-30	_____	-30	_____
75.1	-30	_____	-30	_____
150	-30	_____	-30	_____
151	-30	_____	-30	_____
300	-30	_____	-30	_____
301	-30	_____	-30	_____
600	-30	_____	-30	_____
601	-30	_____	-30	_____
750	-30	_____	-30	_____
950	-30	_____	-30	_____
1200	-30	_____	-30	_____
1201	-30	_____	-25	_____
1500	-30	_____	-30	_____
1900	-30	_____	-30	_____
2400	-30	_____	-30	_____

Table 5-17 Carrier harmonic tests at +7 dBm

Carrier frequency (MHz)	2nd harmonic max. level (dBc)	Result (MHz)	3rd harmonic max. level (dBc)	Result (MHz)
0.01	-30	_____	-30	_____
0.1	-30	_____	-30	_____
1	-30	_____	-30	_____
9.9	-30	_____	-30	_____
10	-30	_____	-30	_____
18.7	-30	_____	-30	_____
18.8	-30	_____	-30	_____
37.4	-30	_____	-30	_____
37.6	-30	_____	-30	_____
74.9	-30	_____	-30	_____
75.1	-30	_____	-30	_____
150	-30	_____	-30	_____
151	-30	_____	-30	_____
300	-30	_____	-30	_____
301	-30	_____	-30	_____
600	-30	_____	-30	_____
601	-30	_____	-30	_____
750	-30	_____	-30	_____
950	-30	_____	-30	_____
1200	-30	_____	-30	_____
1201	-30	_____	-30	_____
1500	-30	_____	-30	_____
1900	-30	_____	-30	_____
2400	-30	_____	-30	_____

ACCEPTANCE TESTING

Table 5-18 Carrier harmonic tests at +13 dBm

Carrier frequency (MHz)	2nd harmonic max. level (dBc)	Result (MHz)	3rd harmonic max. level (dBc)	Result (MHz)
0.01	-25	_____	-25	_____
0.1	-25	_____	-25	_____
1	-25	_____	-25	_____
9.9	-25	_____	-25	_____
10	-25	_____	-25	_____
18.7	-25	_____	-25	_____
18.8	-25	_____	-25	_____
37.4	-25	_____	-25	_____
37.6	-25	_____	-25	_____
74.9	-25	_____	-25	_____
75.1	-25	_____	-25	_____
150	-25	_____	-25	_____
151	-25	_____	-25	_____
300	-25	_____	-25	_____
301	-25	_____	-25	_____
600	-25	_____	-25	_____
601	-25	_____	-25	_____
750	-25	_____	-25	_____
950	-25	_____	-25	_____
1200	-25	_____	-25	_____
1201	-25	_____	-25	_____
1500	-25	_____	-25	_____
1900	-25	_____	-25	_____
2400	-25	_____	-25	_____

Table 5-19 Carrier harmonic tests at +19 dBm

Carrier frequency (MHz)	2nd harmonic max. level (dBc)	Result (MHz)	3rd harmonic max. level (dBc)	Result (MHz)
0.01	-25	_____	-25	_____
0.1	-25	_____	-25	_____
1	-25	_____	-25	_____
9.9	-25	_____	-25	_____
10	-25	_____	-25	_____
18.7	-25	_____	-25	_____
18.8	-25	_____	-25	_____
37.4	-25	_____	-25	_____
37.6	-25	_____	-25	_____
74.9	-25	_____	-25	_____
75.1	-25	_____	-25	_____
150	-25	_____	-25	_____
151	-25	_____	-25	_____
300	-25	_____	-25	_____
301	-25	_____	-25	_____
600	-25	_____	-25	_____
601	-25	_____	-25	_____
750	-25	_____	-25	_____
950	-25	_____	-25	_____
1200	-25	_____	-25	_____

ACCEPTANCE TESTING

Table 5-20 Carrier non-harmonic tests

Carrier frequency (MHz)	Sub-harmonic output			Sub-harmonic output		
	Non-harmonic frequency (MHz)	Non-harmonic level (dBc)	Result (dBc)	Non-harmonic frequency (MHz)	Non-harmonic level (dBc)	Result (dBc)
1201	800.6667	-64	_____	1601.3333	-64	_____
1201	400.3333	-64	_____	2001.6667	-64	_____
1599	1066	-64	_____	2132	-64	_____
1599	533	-64	_____	2665	-64	_____
1601	1200.75	-64	_____	2001.25	-64	_____
1601	800.5	-64	_____	2401.5	-64	_____
1999	1499.25	-64	_____	2498.75	-64	_____
1999	999.5	-64	_____	2998.5	-64	_____
2001	1600.8	-60	_____	2401.2	-60	_____
2001	1200.6	-60	_____	2801.4	-60	_____
2400	1920	-60	_____	2880	-60	_____
2400	1440	-60	_____	3360	-60	_____
9.9	100.000032	-70	_____	109.900036	-70	_____

Table 5-21 Residual FM test

Carrier frequency	Residual FM	Measured value (Hz RMS)
1 GHz	<4.5 Hz RMS	_____

Table 5-22 SSB phase noise test

Carrier frequency	SSB phase noise at 20 kHz offset	Measured value (dBc/Hz)
470 MHz	<-121 dBc/Hz	_____

Table 5-23 Internal FM deviation and distortion tests at 100 kHz deviation

Carrier frequency (MHz)	FM Deviation			Distortion	
	FM deviation min. (kHz)	Result (kHz)	FM deviation max. (kHz)	Distortion (%)	Result (%)
10	95	_____	105	<3%	_____
10.144	95	_____	105	<3%	_____
10.292	95	_____	105	<3%	_____
10.441	95	_____	105	<3%	_____
10.592	95	_____	105	<3%	_____
10.746	95	_____	105	<3%	_____
10.901	95	_____	105	<3%	_____
11.059	95	_____	105	<3%	_____
11.22	95	_____	105	<3%	_____
11.382	95	_____	105	<3%	_____
11.547	95	_____	105	<3%	_____
11.714	95	_____	105	<3%	_____
11.884	95	_____	105	<3%	_____
12.056	95	_____	105	<3%	_____
12.23	95	_____	105	<3%	_____
12.5	95	_____	105	<3%	_____
12.587	95	_____	105	<3%	_____
12.77	95	_____	105	<3%	_____
12.995	95	_____	105	<3%	_____
13.143	95	_____	105	<3%	_____
13.333	95	_____	105	<3%	_____

ACCEPTANCE TESTING

Table 5-24 FM scale shape tests at 15 MHz carrier

FM deviation (kHz)	FM deviation min. (kHz)	Result (kHz)	FM deviation max. (kHz)
100	95	_____	105
71	67.45	_____	74.55
56	53.2	_____	58.8
44	41.8	_____	46.2
34	32.3	_____	35.7
27	25.65	_____	28.35
21	19.95	_____	22.05
16	15.2	_____	16.8
13	12.35	_____	13.65
11	10.45	_____	11.55
10	9.5	_____	10.5
1	0.95	_____	1.05
0.1	0.095	_____	0.105

Table 5-25 Carrier error test at 1.2 GHz, FM deviation 100 kHz

Carrier error	Result (kHz)
<1 kHz	_____

Table 5-26 External FM frequency response (ALC off, DC coupled), 50 kHz deviation

Modulation frequency (kHz)	Response level min. (dB)	Result (dB)	Response level max. (dB)	Distortion (%)	Result (%)
0	-1	_____	+1	-	-
0.03	-1	_____	+1	-	-
0.1	-1	_____	+1	<3	_____
0.3	-1	_____	+1	-	-
1	-	reference	-	<3	_____
3	-1	_____	+1	-	-
5	-1	_____	+1	<3	_____
10	-1	_____	+1	-	-
20	-1	_____	+1	<3	_____
50	-1	_____	+1	-	-
100	-1	_____	+1	-	-

Table 5-27 External FM frequency response (ALC on), 10 kHz deviation, 0.75 V input

Modulation frequency (kHz)	Response level min. (dB)	Result (dB)	Response level max. (dB)
0.02	-1	_____	+1
0.1	-1	_____	+1
0.3	-1	_____	+1
1	-	reference	-
3	-1	_____	+1
10	-1	_____	+1
30	-1	_____	+1
100	-1	_____	+1

Table 5-28 External FM frequency response (ALC on), 10 kHz deviation, 1.25 V input

Modulation frequency (kHz)	Response level min. (dB)	Result (dB)	Response level max. (dB)	Distortion (%)	Result (%)
0.02	-1	_____	+1	-	-
0.1	-1	_____	+1	<3	_____
0.3	-1	_____	+1	-	-
1	-	reference	-	<3	_____
3	-1	_____	+1	-	-
5	-1	_____	+1	<3	_____
10	-1	_____	+1	-	-
20	-1	_____	+1	<3	_____
30	-1	_____	+1	-	-
100	-1	_____	+1	-	-

ACCEPTANCE TESTING

Table 5-29 Internal Φ M and distortion test at 10.5 MHz carrier, 10 rad deviation

Φ M deviation			Distortion	
Φ M deviation min. (rad)	Result (rad)	Φ M deviation max. (rad)	Distortion (%)	Result (%)
9.5	_____	10.5	<3%	_____

Table 5-30 Internal Φ M flatness test

Modulation frequency (kHz)	Response level min. (dB)	Result (dB)	Response level max. (dB)
0.1	-3	_____	+3
0.3	-3	_____	+3
1	-	reference	-
3	-3	_____	+3
10	-3	_____	+3

Table 5-31 Internal AM depth and distortion tests at -4 dBm

Carrier frequency (MHz)	AM depth 30%			AM depth 80%			Distortion	
	min. (%)	Result (%)	max. (%)	min. (%)	Result (%)	max. (%)	Result at 30% depth (<1.5%)	Result at 80% depth (<2.5%)
1.5	28.5	_____	31.5	76	_____	84	_____	_____
5	28.5	_____	31.5	76	_____	84	_____	_____
9	28.5	_____	31.5	76	_____	84	_____	_____
11	28.5	_____	31.5	76	_____	84	_____	_____
20	28.5	_____	31.5	76	_____	84	_____	_____
50	28.5	_____	31.5	76	_____	84	_____	_____
100	28.5	_____	31.5	76	_____	84	_____	_____
200	28.5	_____	31.5	76	_____	84	_____	_____
500	28.5	_____	31.5	76	_____	84	_____	_____

Table 5-32 Internal AM depth and distortion tests at 0 dBm

Carrier frequency (MHz)	AM depth 30%			AM depth 80%			Distortion	
	min. (%)	Result (%)	max. (%)	min. (%)	Result (%)	max. (%)	Result at 30% depth (<1.5%)	Result at 80% depth (<2.5%)
1.5	28.5	_____	31.5	76	_____	84	_____	_____
5	28.5	_____	31.5	76	_____	84	_____	_____
9	28.5	_____	31.5	76	_____	84	_____	_____
11	28.5	_____	31.5	76	_____	84	_____	_____
20	28.5	_____	31.5	76	_____	84	_____	_____
50	28.5	_____	31.5	76	_____	84	_____	_____
100	28.5	_____	31.5	76	_____	84	_____	_____
200	28.5	_____	31.5	76	_____	84	_____	_____
500	28.5	_____	31.5	76	_____	84	_____	_____

Table 5-33 Internal AM depth and distortion tests at +7 dBm

Carrier frequency (MHz)	AM depth 30%			AM depth 80%			Distortion	
	min. (%)	Result (%)	max. (%)	min. (%)	Result (%)	max. (%)	Result at 30% depth (<1.5%)	Result at 80% depth (<2.5%)
1.5	28.5	_____	31.5	76	_____	84	_____	_____
5	28.5	_____	31.5	76	_____	84	_____	_____
9	28.5	_____	31.5	76	_____	84	_____	_____
11	28.5	_____	31.5	76	_____	84	_____	_____
20	28.5	_____	31.5	76	_____	84	_____	_____
50	28.5	_____	31.5	76	_____	84	_____	_____
100	28.5	_____	31.5	76	_____	84	_____	_____
200	28.5	_____	31.5	76	_____	84	_____	_____
500	28.5	_____	31.5	76	_____	84	_____	_____

ACCEPTANCE TESTING

Table 5-34 AM scale shape test

AM depth (%)	AM depth min. (%)	Result (%)	AM depth max. (%)
10	9.5	_____	10.5
20	19	_____	21
30	28.5	_____	31.5
40	38	_____	42
50	47.5	_____	52.5
60	57	_____	63
70	66.5	_____	73.5
80	76	_____	84
85	80.75	_____	89.25

Table 5-35 External AM frequency response (ALC off, DC coupled), RF level -4 dBm

Modulation frequency (kHz)	Response level min. (dB)	Result (dB)	Response level max. (dB)
0	-1	_____	+1
0.1	-1	_____	+1
0.3	-1	_____	+1
1	-	reference	-
10	-1	_____	+1
20	-1	_____	+1
30	-1	_____	+1

Table 5-36 External AM frequency response (ALC off, DC coupled), RF level +7 dBm

Modulation frequency (kHz)	Response level min. (dB)	Result (dB)	Response level max. (dB)
0	-1	_____	+1
0.1	-1	_____	+1
0.3	-1	_____	+1
1	-	reference	-
10	-1	_____	+1
20	-1	_____	+1
30	-1	_____	+1

ACCEPTANCE TESTING

Table 5-37 Pulse modulation RF output at -7 dBm

Carrier frequency (MHz)	RF level min. (dBm)	Result (dBm)	RF level max. (dBm)
30	-8.3	_____	+5.7
60	-8.3	_____	+5.7
180	-8.3	_____	+5.7
300	-8.3	_____	+5.7
420	-8.3	_____	+5.7
540	-8.3	_____	+5.7
660	-8.3	_____	+5.7
780	-8.3	_____	+5.7
900	-8.3	_____	+5.7
1020	-8.3	_____	+5.7
1140	-8.3	_____	+5.7
1200	-8.3	_____	+5.7
1201	-9.1	_____	+4.9
1260	-9.1	_____	+4.9
1380	-9.1	_____	+4.9
1500	-9.1	_____	+4.9
1620	-9.1	_____	+4.9
1740	-9.1	_____	+4.9
1860	-9.1	_____	+4.9
1980	-9.1	_____	+4.9
2220	-9.1	_____	+4.9
2340	-9.1	_____	+4.9
2400	-9.1	_____	+4.9

Table 5-38 Pulse modulation RF output at +4 dBm

Carrier frequency (MHz)	RF level min. (dBm)	Result (dBm)	RF level max. (dBm)
30	+2.7	_____	+5.3
60	+2.7	_____	+5.3
180	+2.7	_____	+5.3
300	+2.7	_____	+5.3
420	+2.7	_____	+5.3
540	+2.7	_____	+5.3
660	+2.7	_____	+5.3
780	+2.7	_____	+5.3
900	+2.7	_____	+5.3
1020	+2.7	_____	+5.3
1140	+2.7	_____	+5.3
1200	+2.7	_____	+5.3
1201	+1.9	_____	+6.1
1260	+1.9	_____	+6.1
1380	+1.9	_____	+6.1
1500	+1.9	_____	+6.1
1620	+1.9	_____	+6.1
1740	+1.9	_____	+6.1
1860	+1.9	_____	+6.1
1980	+1.9	_____	+6.1
2220	+1.9	_____	+6.1
2340	+1.9	_____	+6.1
2400	+1.9	_____	+6.1

ACCEPTANCE TESTING

Table 5-39 Pulse modulation on/off ratio test

Carrier frequency (MHz)	Pulse mod. on/off ratio (dB)	Measured value (dB)
32	>45	_____
100	>45	_____
320	>45	_____
1000	>45	_____
1200	>45	_____
1500	>40	_____
1800	>40	_____
2100	>40	_____
2400	>40	_____

Table 5-40 Pulse modulation rise and fall time test

		Result (μ s)
Rise time	<10 μ s	_____
Fall time	<10 μ s	_____

Table 5-41 Modulation oscillator frequency tests

Frequency (Hz)	Result (Hz)
10	_____
100	_____
1000	_____
20000	_____

Table 5-42 Modulation oscillator distortion and LF output tests

Mod. oscillator frequency (Hz)	Response level min. (dB)	Result	Response level max. (dB)	Distortion (%)	Result (%)
10	-1	_____	+1	-	-
20	-1	_____	+1	-	-
50	-1	_____	+1	-	-
100	-1	_____	+1	-	-
200	-1	_____	+1	-	-
500	-1	_____	+1	-	-
1000	-1	reference	-	<0.1%	_____
2000	-1	_____	+1	-	-
5000	-1	_____	+1	-	-
10000	-1	_____	+1	-	-
20000	-1	_____	+1	-	-

Table 5-43 External frequency standard tests

External signal	Locked [✓]
1 MHz, 220 mV	[]
1 MHz, 1.8 V	[]
10 MHz, 220 mV	[]
10 MHz, 1.8 V	[]

ACCEPTANCE TESTING

Index

A

About this manual	ii
Acceptance testing.....	5-1
Accessories.....	1-6
ALC linearity test.....	5-6
AM depth and distortion test.....	5-18
AM scale shape test.....	5-19
Amplitude modulation.....	3-18
Amplitude modulation test.....	5-18
Attenuator accuracy test.....	5-7
Attenuator hold.....	3-29

B

Beryllia.....	v
Binary FSK.....	3-12

C

Carrier error test.....	5-15
Carrier frequency.....	3-8
Carrier frequency accuracy test.....	5-8
Carrier phase offset.....	3-8
Cleaning.....	2-2
Conventions for key labelling.....	ii
Coupling event registers.....	3-37

D

DC FM nulling.....	3-14
DC supply voltage.....	iv
Default settings.....	3-7
Disk installation/loading instructions.....	2-4

E

EMF or PD.....	3-9
Error messages.....	3-43
External AM frequency response test.....	5-19
External FM frequency response test.....	5-15, 5-16
External frequency standard input test.....	5-24

F

Fire hazards.....	v
FM deviation and distortion test.....	5-14
FM scale shape test.....	5-14
Frequency modulation selection.....	3-14
Frequency standard selection.....	3-32
Front panel.....	2-3
FSK.....	3-14
Fuses.....	2-2

H

Hardware event registers.....	3-36
-------------------------------	------

Harmonics test.....	5-10
Hazard symbols.....	iv

I

IEEE 488.2 mnemonics

AM.....	3-18
ATTEN.....	3-29
ATTEN?.....	3-29
CCR?.....	3-42
CFRQ.....	3-8
CFRQ?.....	3-8, 3-25
COUNT?.....	3-31
*CLS.....	3-6
CSE.....	3-42
CSE?.....	3-42
CSR?.....	3-42
ELAPSED.....	3-31
ELAPSED?.....	3-31
ERROR?.....	3-32
*ESE.....	3-6
*ESE?.....	3-6
*ESR?.....	3-6
FM.....	3-14
FM?.....	3-15
FSTD.....	3-32
FSTD?.....	3-32
HCR?.....	3-42
HSE.....	3-42
HSE?.....	3-42
HSR?.....	3-42
*IDN?.....	3-5
MOD.....	3-13
MOD?.....	3-13
MODE.....	3-12
MODE?.....	3-12
MODF?.....	3-15, 3-17, 3-19
MPROT.....	3-24
MSEQ.....	3-23
MSEQ?.....	3-23
MTRIG.....	3-24
MTRIG?.....	3-24
*OPC.....	3-6
*OPC?.....	3-6
OPER?.....	3-31
*OPT?.....	3-5
PM.....	3-16
POWUP.....	3-30
IEEE 488.2 mnemonics (contd.)	
POWUP?.....	3-30
PULSE.....	3-20
PULSE?.....	3-20

RCL 3-22
RFLV 3-9, 3-11
RFLV? 3-10, 3-11
RPP 3-31
*RST 3-6
SCR? 3-42
SOURCE? 3-28
*SRE 3-6
*SRE? 3-6
SSE 3-42
SSE? 3-42
SSR? 3-42
*STB? 3-6
STO 3-21, 3-27
SWEEP 3-25, 3-26
SWEEP? 3-26
*TRG 3-6
TRIGGER 3-28
TRIPPED? 3-31
*TST? 3-6
*WAI 3-6
Initial visual inspection 2-1
Installation and power-up 2-1
Installing in VXI mainframe 2-2
Instrument event registers 3-38
Internal FM test 5-13
Internal fuses 2-2

M

Main features 1-1
Memory - erase 3-23
Memory - protection 3-24
Memory - sequencing 3-23
Memory - triggering 3-24
Memory recall 3-22
Memory stores 3-21
Modulation control 3-13
Modulation mode 3-12
Modulation oscillator distortion and LF output
flatness test 5-24
Modulation oscillator frequencies test 5-23
Modulation oscillator test 5-22

N

Naming conventions ii
Non-harmonics test 5-11

O

Operating hours 3-31
Output control 3-11

P

Performance data 1-3
Phase modulation flatness test 5-17
Phase modulation test 5-17

Power-up options 3-30
Programming 3-1
Pulse modulation 3-20
Pulse modulation on/off ratio test 5-21
Pulse modulation RF level frequency response
test 5-21
Pulse modulation rise and fall time test 5-22
Pulse modulation test 5-21
Putting into storage 2-3

Q

Quadrature FSK 3-12
Queue flag details 3-39

R

Reading error messages 3-32
Recommended test equipment 5-4
Residual FM test 5-11
Reverse power protection 3-31
RF level 3-9
RF level frequency response test 5-6
RF level limit 3-9
RF level offset 3-9
RF output test 5-5
Routine safety testing and inspection 2-2

S

Setting logical address 2-1
Spectral purity test 5-9
SSB phase noise test 5-12
Standard event registers 3-35
Status byte 3-33, 3-40, 3-41
Status data structure 3-34
Sweep mode 3-26
Sweep operation 3-25
Switching on 2-4

T

Test precautions 5-3
Toxic hazards v
Trigger source 3-28

V

Ventilation requirements 2-1
Voltage restraint v

RACAL INSTRUMENTATION GROUP ADDRESSES

Racal Instruments Ltd.

480 Bath Road, Slough, Berkshire SL1 6BE, United Kingdom
Tel: +44 (0) 1628 604455 Telex: 847020 Fax: +44 (0) 1628 662017

Racal Instruments Inc

4 Goodyear Street, P.O.Box C-19541, Irvine Ca 92718, USA
Tel: +1 714 859 8999 Telex: 678341 Fax: +1 714 859 2505

Racal Systems Electronique S.A.

18 Avenue Dutartre, 78150 Le Chesnay, France.
Tel: +33 (1) 3955 8888 Telex: 697215 Fax: +33 (1) 3955 6735

Racal Systems Elettronica Srl

Strada 2 - Palazzo C4, 20090 Milanofiori Assago MI, Italy.
Tel: +39 (2) 5750 1796 Fax: +39 (2) 5750 1828

RACAL ELECTRONIC SYSTEM GmbH

Frankenforster Strasse 21, 51427 Bergisch Gladbach 1, Germany.
Tel: +49 2204 9222-0 Fax: +49 2204 21491



